

# Kollmorgen Automation and Motion Solutions Catalog



Micron™ Gearheads



AKM™ Servomotors



Kollmorgen Cartridge DDR™ Motors



Housed Direct Drive Rotary Motors



Direct Drive Linear Motors



Linear Positioners



Multi-Axis Precision Tables

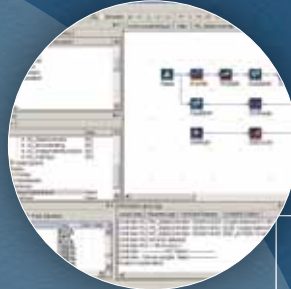

Kollmorgen Automation Suite™



AKC™ Programmable Automation Controllers



AKD PDM™



AKD™ Servo Drives

**KOLLMORGEN**®

*Because Motion Matters™*

Sold & Serviced By:

 **ELECTROMATE**

Toll Free Phone (877) SERV098

Toll Free Fax (877) SERV099

[www.electromate.com](http://www.electromate.com)

[sales@electromate.com](mailto:sales@electromate.com)

# Kollmorgen. Every solution comes from a real understanding of the challenges facing machine designers and users.

**The ever-escalating demands of the marketplace mean increased pressure on machine designers and users at every turn.** Time constraints. Demands for better performance. Having to think about the next-generation machine even before the current one is built. While expectations are enormous, budgets are not. Kollmorgen's innovative automation and motion solutions and broad range of quality products help engineers not only overcome these challenges but also build truly differentiated machines.

**Because motion matters, it's our focus.** Motion can distinctly differentiate a machine and deliver a marketplace advantage by improving its performance. This translates to overall increased efficiency on the factory floor. Perfectly deployed machine motion can make your customer's machine more reliable and efficient, enhance accuracy and improve operator safety. Motion also represents endless possibilities for innovation. We've always understood this potential, and thus, have kept motion at our core, relentlessly developing products that offer precision control of speed, accuracy and position in machines that rely on complex motion.

Sold & Serviced By:

 **ELECTROMATE**

Toll Free Phone (877) SERV098

Toll Free Fax (877) SERV099

[www.electromate.com](http://www.electromate.com)

[sales@electromate.com](mailto:sales@electromate.com)

**Removing the Barriers of Design, Sourcing, and Time**

At Kollmorgen, we know that OEM engineers can achieve a lot more when obstacles aren't in the way. So, we knock them down in three important ways:

**Integrating Standard and Custom Products**

The optimal solution is often not clear-cut. Our application expertise allows us to modify standard products or develop totally custom solutions across our whole product portfolio so that designs can take flight.

**Providing Solutions, Not Just Components**

As companies reduce their supplier base and have less engineering manpower, they need a total system supplier with a wide range of integrated solutions. Kollmorgen is in full response mode with complete solutions that combine programming software, engineering services and best-in-class components.

**Global Footprint**

With direct sales, engineering support, manufacturing facilities, and distributors across North America, Europe, the Middle East, and Asia, we're close to OEMs worldwide. Our proximity helps speed delivery and lend support where and when they're needed.

**Financial and Operational Stability**

Kollmorgen is part of Danaher Corporation, our \$14B parent company. A key driver in the growth of all Danaher divisions is the Danaher Business System, which relies on the principle of "kaizen" – or continuous improvement. Using world-class tools, cross-disciplinary teams of exceptional people evaluate processes, and develop plans that result in superior performance.

# Table of Contents

▶ <b>Kollmorgen Automation Suite™</b>	K2
▶ <b>AKD™ Servo Drive</b>	2
▶ <b>AKD™ Servo Systems</b>	20
<b>AKM™ Servomotor</b>	22
<b>Direct Drive Technology</b>	28
<b>Cartridge Direct Drive Rotary™ (DDR) Motor</b>	30
<b>Housed Direct Drive Rotary Motor</b>	34
<b>Linear Positioning System</b>	36
<b>Precision Tables DS4 / DS6 Series</b>	38
<b>Electric Cylinders N2 / EC Series</b>	42
<b>Rodless Actuators R-Series</b>	48
<b>Micron™ TRUE Planetary™ Gearhead</b>	54
▶ <b>Stepper Products</b>	58
▶ <b>Optimized Solutions</b>	62
▶ <b>Cables by Motor Type</b>	66
▶ <b>Model Nomenclature</b>	67
▶ <b>MOTIONEERING® Application Engine</b>	83

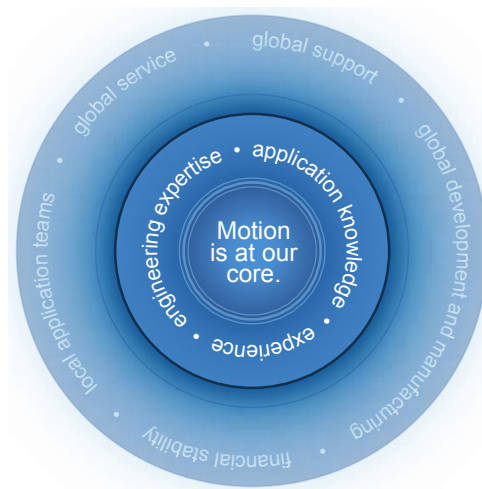

# Kollmorgen Automation Suite™

K O L L M O R G E N   A U T O M A T I O N   S U I T E

Kollmorgen's machine automation solution dramatically simplifies how you approach the many complex automation challenges of today's machines. We have put together an integrated system that encompasses three facets – the integrated development environment, engineering services, and our best-in-class automation and motion components – to help create a differentiated machine, get to market faster, and have the ease of collaborating with just one vendor.

**Integrated Development Environment** – Quickly and easily design, refine and troubleshoot all of a machine's automated solutions in this highly intuitive application featuring a single programming environment that provides great flexibility and control.

**Engineering Services** – A Kollmorgen representative establishes a collaborative, consultative relationship from the beginning by assessing needs and objectives. Then, an electronic sketch of a machine concept is generated using our System Designer drag-and-drop software, specifying all the necessary components including creation of a sample bill of materials. Field engineers and application engineers constantly support the design and build phase as well as the factory installation phase to ensure that your needs are met from concept to production. Additional services are available that include start-up and troubleshooting assistance, development and on-site deployment and training.

**Best-in-Class Automation and Motion Components** – With Kollmorgen, there's security in knowing the necessary components that form the building blocks of a machine are always available. No one offers a wider range of standard, modified standard and custom products.

**Kollmorgen Co-engineering** – More than a solutions provider, we Co-engineer a better fit with your company using both products and services. From a wide breadth of product modifications, over 500,000 standard options with 5-day delivery on our AKM line, to aftermarket revenue protection and training programs, Kollmorgen Co-engineering helps you differentiate your machine and business.

We accept your challenges as our own. That's the Kollmorgen Co-engineering difference.

Sold & Serviced By:

 **ELECTROMATE**

Toll Free Phone (877) SERV098

Toll Free Fax (877) SERV099

[www.electromate.com](http://www.electromate.com)

[sales@electromate.com](mailto:sales@electromate.com)

## The Benefits of Kollmorgen Automation Suite

- |   |   |
|---|---|
| <ul style="list-style-type: none"> <li>• Powerful High-Performance Machines</li> </ul>  | <ul style="list-style-type: none"> <li>• Up to 25% greater throughput</li> <li>• Up to 50% scrap reduction</li> <li>• Improved accuracy</li> <li>• Advanced motion to enable unique machine performance</li> </ul>  |
| <ul style="list-style-type: none"> <li>• Deliver Machines to Market Faster</li> </ul>   | <ul style="list-style-type: none"> <li>• Up to 30% reduction in development time</li> <li>• Services available for program development, training, start-up, and support</li> <li>• Industry standard programming environment and industrial networks</li> </ul>   |
| <ul style="list-style-type: none"> <li>• Real-time, Highly Intuitive Development Software with Enhanced Ease-of-Use and Seamless Integration</li> </ul> | <ul style="list-style-type: none"> <li>• Single integrated programming environment for automation, motion and all hardware</li> <li>• Drag-and-drop motion programming</li> <li>• Certified best-in-class components that are tested to work together</li> <li>• Seamless drive integration and configuration for optimal drive set-up</li> </ul>   |
| <ul style="list-style-type: none"> <li>• Complete and Proven Machine Automation Solution</li> </ul>   | <ul style="list-style-type: none"> <li>• The result of over 20 years of refining automation and motion programming and implementation</li> <li>• Combines the best of our engineering experience across the multiple suppliers and platforms that form today's Kollmorgen</li> <li>• Kollmorgen Automation Suite has undergone over five years of extensive field testing in customer applications</li> </ul> |

Sold & Serviced By:

 **ELECTROMATE**

Toll Free Phone (877) SERV098

Toll Free Fax (877) SERV099

[www.electromate.com](http://www.electromate.com)

[sales@electromate.com](mailto:sales@electromate.com)

# Kollmorgen Automation Suite

Kollmorgen Automation Suite is an integrated set of tools and components that help the automation system designer build high-performance machines.

- The customer solution is programmed using the integrated development environment. The resulting user application is deployed on the AKC™ Programmable Automation Controller (PAC) or AKD™ PDMM™ Integrated Servo Drive and Automation Controller. Ease-of-use features built into the product family ensure that the development process is accelerated.
- The AKC family has been created with an eye towards simplifying choices to the required level. And our extensive experience means that you receive the correct recommendations on the platform of choice. The AKD PDMM provides many of the capabilities of our AKC PAC product for applications of up to 8 or more axes in a package that includes an integrated AKD servo drive axis.
- The AKC PAC and AKD PDMM communicate with AKD servo drives and AKT™ I/O terminals using the EtherCAT® motion bus. EtherCAT provides a real-time deterministic network for fast response and high-performance.
- AKI™ Human Machine Interfaces (HMI) are connected to the AKC PAC and AKD PDMM using ModBus TCP for simple and reliable communication with quick and easy set-up.
- AKD drives can operate a wide range of Kollmorgen motors including the industry-leading AKM™ standard rotary servomotor. Micron™ TRUE Planetary™ gearheads are available to complete the system. Additionally unique solutions like the Cartridge Direct Drive Rotary™ motor as well as other direct drive rotary and linear motors let you choose the optimum solution for your system needs.
- All required motor/drive and network cables are available to ensure interoperability and fast time to an operating system.
- As a machine builder or an OEM manufacturer, you can focus on machine performance and key customer requirements while Kollmorgen provides you with complementary intellectual value, expertise, and economies of scale with a streamlined product family.

Our certified components mean that the commissioning and start-up process is faster. Our new servo drive, the AKD, is integrated into the product line to deliver the next generation of servo technology. With the award-winning motor and drive component families integrated into the solution set, the customer receives significant reduction in start-up and commissioning effort due to the provided auto-recognize and auto-configure features.

Kollmorgen Automation Suite also comes with extensive engineering, support, and training services available. Our experience in creating and optimizing applications for performance means that you always create a solution that outperforms to deliver higher productivity for your engineering teams and production machines.

Sold & Serviced By:



Toll Free Phone (877) SERV098

Toll Free Fax (877) SERV099

[www.electromate.com](http://www.electromate.com)

[sales@electromate.com](mailto:sales@electromate.com)

### Development Software with Integrated Human Machine Interface (HMI) Support and CAM Tools



### Programmable Automation Controllers (PAC) and Integrated Servo Drive/Automation Controllers



Integrated Touch Panel

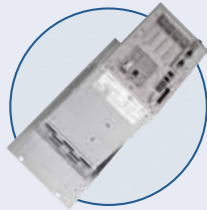

Rack-Mount



Standard



AKD Servo Drive Integrated

### HMI, I/O, and System Cables



HMI

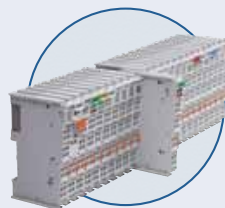

I/O



Motor and Feedback Cables



Network Cables

### AKD Servo Drives, Motors, and Gearheads



AKD Servo Drives

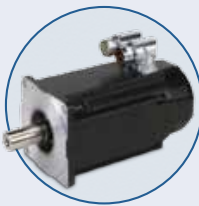

AKM Servomotors



Cartridge DDR Motors



Micron Gearheads

Sold & Serviced By:

 **ELECTROMATE**

Toll Free Phone (877) SERV098

Toll Free Fax (877) SERV099

[www.electromate.com](http://www.electromate.com)

[sales@electromate.com](mailto:sales@electromate.com)

# Software PLC

## Easy-to-Use, Auto-Discover, Auto-Recognize, Auto-Configure, Scope, CAM, IEC 61131-3 PLC

- Kollmorgen Automation Suite offers an integrated set of tools that allow the automation systems programmer to achieve quality software results. This includes not only our motion control solution set, but also the industry standard IEC 61131-3 toolkit for PLC programming.
- The environment for developing PLC programs has been created to help the engineer create solutions faster. Recognize and configure motion control components to accelerate systems development. With auto-recognize and auto-configure features, testing efforts are reduced.
- Once an application or a function block has been created for a given application, the user can store this as a “user-defined function block” to promote reuse of tested software in subsequent projects to save time.
- Maintain your standards in corporate programming languages by using any of the IEC 61131-3 languages. In fact, enhance it further by mixing and matching languages to deliver the best solution for the application.
- Kollmorgen Automation Suite’s integrated development environment allows the developer to create solutions without having to connect a single device by using the offline simulator. This lets you start creating systems before the first hardware component is delivered. Simply configure your system network in “offline development” mode and change the status of the devices when you actually connect them.
- Standard debugging features like step into, step over, etc. are available to troubleshoot programs. In addition, debugging support is available in the form of a soft oscilloscope into which several variables can be plugged in – the display can also be configured to suit the scale that the developer desires.
- Our excellent CAM editor lets you create complex CAM profiles online using a graphical interface. It is also possible to import existing CAM profile points into the CAM editor to allow you to seamlessly reuse your existing machine building experience.

The screenshot displays the Kollmorgen Automation Suite software interface, showcasing various PLC programming languages supported by the IEC 61131-3 standard. The interface is divided into several panels:

- Sequential Function Chart (SFC):** A vertical flowchart with steps (1-4) and transitions, used for sequencing operations.
- Function Block Diagram (FBD):** A graphical representation of a PLC program using interconnected function blocks.
- Ladder Diagram (LD):** A traditional PLC programming language using logic gates and coils.
- Structured Text (ST):** A text-based programming language for PLC, showing code for enabling axes and handling motion stop events.
- Instruction List (IL):** A list-based programming language, showing a sequence of instructions like LD, AND, JNPC, and JNP.

```
Structured Text (ST)
On Machine_Enable TRUE DO //Enable Axis
MLAxisPower( PipeNetwork.AXIS1 22 ,
MLAxisPower( PipeNetwork.AXIS2 31 ,
END_DO;

IF FALSE Machine_Enable TRUE = 0 and St
MLAxisPower( PipeNetw
END_IF;

IF FALSE Machine_Enable
MLAxisPower( PipeNetw
END_IF;

//Stop Motion button pre
ON b_GC_StopMotion FALSE
MLMstRun( PipeNetwork
b_GC_StartMotion TRU
END_DO;
```

```
Instruction List (IL)
Begin_IL
LD Input1 TRUE
AND Input2 FALSE
JNPC Test
//Store Result
ST Output FALSE
JNP End
Test:
//Store Input1
LD Input1 TRUE
ST Output FALSE
END;
END_IL
```

All five IEC 61131-3 PLC languages are supported





Customizable environment for docking/undocking and floating panels on the screen  
 Watch window to closely monitor special variables  
 Filter information and log messages to focus on the essentials  
 Ability to customize the environment and set parameters across the environment

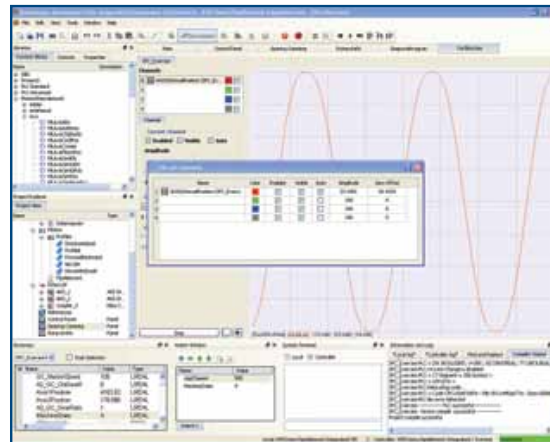

Built-in soft oscilloscope

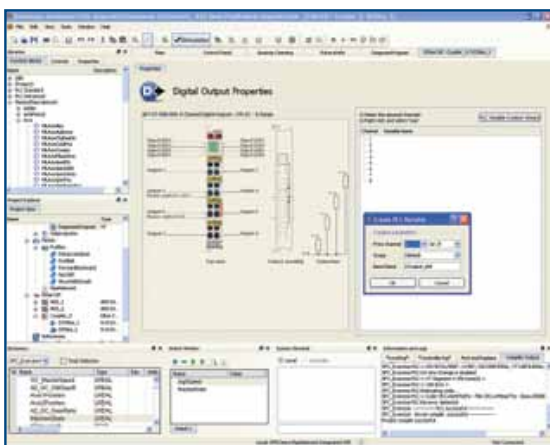

Automatic I/O variable creation with scope definitions  
 Adding bus couplers with I/Os onto a motion network topology



Simulator with PLC simulation and motion

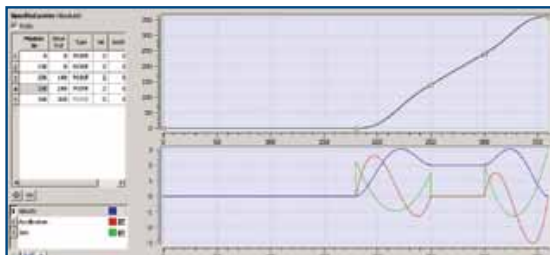

Graphical environment for creating CAMs

# Motion Programming

Our solution offering in motion control is backed by vast experience solving customer problems in the industry. We recognize that customers may want standard solutions for reuse of existing knowledge and resource bases or may want customized solutions that offer differentiation. To this end, we offer two motion control programming solutions.

## PLCopen for motion

With Kollmorgen Automation Suite, you can program systems using the industry standard PLCopen for motion. It is an open standard ([www.plcopen.org](http://www.plcopen.org)) with wide acceptance. Also, it is an industry standard that is vendor and product independent. PLCopen for motion provides a framework to build industry-specific motion blocks.

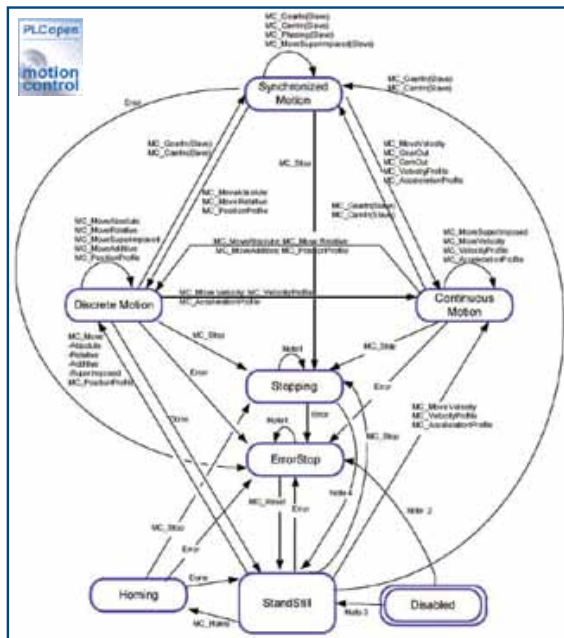

PLCopen state diagram

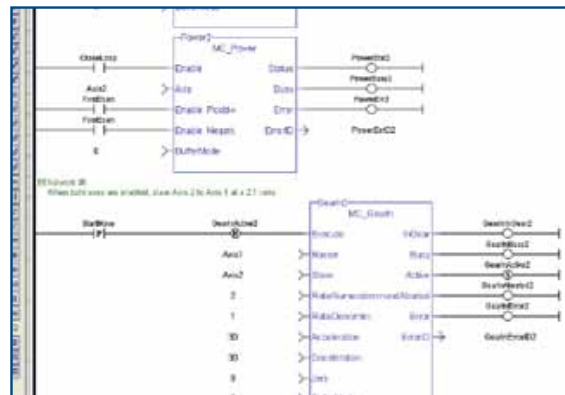

PLCopen example program code

## Pipe Network™

Graphical programming using the Pipe Network is a Kollmorgen innovation from many years of experience and it has been fine-tuned to deliver exceptional performance to motion-centric applications. Motion control building blocks have been converted into drag-and-drop icons that can be used to create motion control solutions. Since it is a graphical programming environment, systems are developed faster, with improved quality, increased self-documentation of system topology, and easier maintenance since a picture conveys the architecture and the relationships between the different axes of a system more effectively. Since it has been in operation for many years, the building blocks have been optimized to deliver higher performance than other solutions in the marketplace.

The solution has a demonstrated record of increased Overall Equipment Effectiveness (OEE), increased productivity, higher accuracy, and scrap reduction.

## Mechanical System

- Main drive moves mechanical system
- Speeds and movements are adapted with mechanical elements, like gear boxes and CAM discs

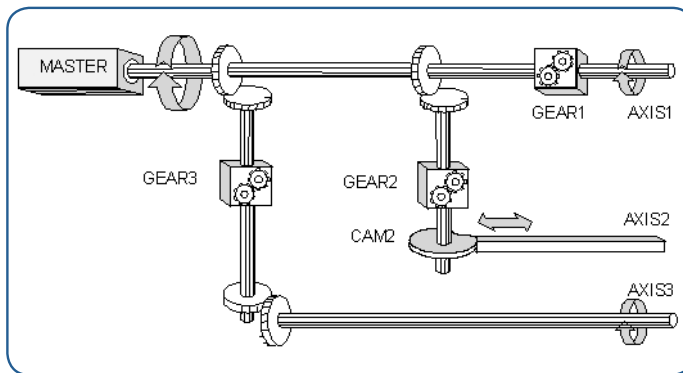

## Pipe Concept

- Main drive is replaced by a virtual master
- Mechanical elements are copied by logical blocks with the same function
- One-to-one replacement of the mechanical system

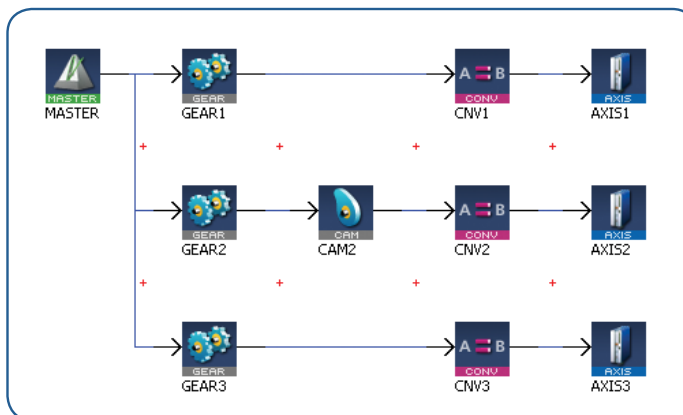

Sold & Serviced By:

 **ELECTROMATE**

Toll Free Phone (877) SERV098

Toll Free Fax (877) SERV099

[www.electromate.com](http://www.electromate.com)

[sales@electromate.com](mailto:sales@electromate.com)

# Real-time Motion Bus

## EtherCAT® Real-time Bus for Motion and I/O Connectivity

- Real-time Ethernet-based motion bus
- Widely-accepted open standard
- Standard Ethernet cabling = lower implementation cost
- High bandwidth utilization for high-performance
- Interoperability with other buses
- Wide availability of devices
- Auto-recognition of Kollmorgen Automation Suite-compatible components

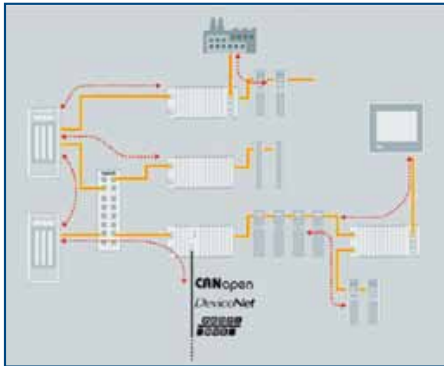

Versatile network architecture

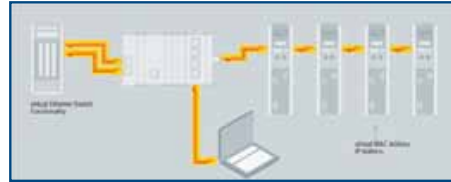

Transparent for all Ethernet protocols

Process Data	Update Time
256 distributed digital I/O	11 $\mu$ s = 0,01 ms
1000 distributed digital I/O	30 $\mu$ s
200 analog I/O (16 bit)	50 $\mu$ s $\leftrightarrow$ 20 kHz
100 Servo Axis, with 8 Bytes input and output data each	100 $\mu$ s
1 Fieldbus Master-Gateway (1486 Bytes Input and 1486 Bytes Output Data)	150 $\mu$ s

EtherCAT performance overview

# HMI Software Tools

## Kollmorgen Automation Suite Visualization Builder™ HMI Software

Kollmorgen Automation Suite Visualization Builder operates from within the Kollmorgen Automation Suite integrated development environment making it quick and easy to create your HMI program and transfer it to the target hardware (either a touch panel PAC or standalone HMI panel).

- Choose application variables (tags) to be used by the Kollmorgen Automation Suite Visualization Builder; a file is automatically created

### Features include

- Multi-screen navigation
- Trending
- Recipes
- Alarm management
- Internal variables
- Multiple text – change of control based on input value
- Function keys
- Security

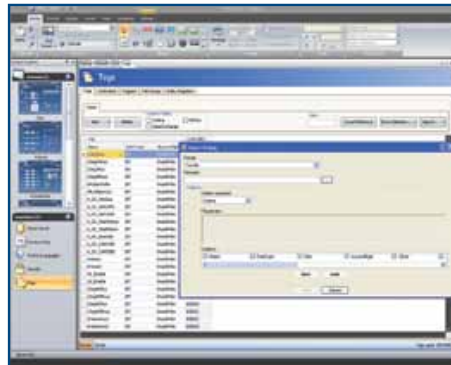

HMI developer environment

# Programmable Automation Controller (PAC)

## AKC™ Programmable Automation Controller

AKC Programmable Automation Controllers are powerful and robust industrial computers with pre-installed software components designed especially for rugged use in close proximity to machinery. Available in models with integrated high-resolution touch panels, in standard (screenless box format), or rack mount (screenless) formats and with a variety of CPU and memory choices. All models are equipped with reliable compact flash drives for application and program storage. They are fully equipped and ready for operation right out of the box for faster time to market.



Integrated Touch Panel

- Built-in high-performance motion and PLC engine running in a real-time operating system (RTOS) for reliable performance.
- Panel PACs offer all of the power and design features of our standard PACs with the addition of your choice of a 10", 15", or 17" integrated display. Combined with Kollmorgen Visualizer RT in your choice of 250, 2000 or 4000 tag runtime licenses, the panel PAC provides a complete integrated solution with high resolution HMI in one package.

## AKC-PNC-D1 High-Performance

Technical Data	AKC-PNC-D1-224-150-00-000	AKC-PNC-D1-224-170-00-000
Display	15.0" TFT	17.0" TFT
Resolution	1024 × 768	1280 × 1024
Brightness	250cd / m <sup>2</sup>	250cd / m <sup>2</sup>
Touchscreen	Resistive analog	
Weight	ca. 8.9 kg	ca. 10.8 kg
Dimensions (HxWxD)	354 × 450 × 163 mm	399 × 461 × 168 mm
Processor	Intel® Core™ 2 Duo 1.86 GHz	
RAM	2 GB	
Compact flash	4 GB	
NVRAM	128 k	
I/O standard	5x USB (1x front, 4x rear side), 1x LAN 10 / 100, 1x LAN 100 / 1000, 2x RS232, 1x DVI-I	
Free slots	2x PCI	
Power supply	24 Vdc	
Cooling	Fanless	
EMC	US:FCC47 CFR PART15; Class A level, CE:EN61000-6-2; EN55022 / A (CISPR22)	
Certifications	CE, FCC, cULus	
Protection class	IP65 front (NEMA 250 Type 12 and 13)	
Altitude	Operating: 10000 ft (3.048 m), Storage: 15000 ft (4.622 m)	
Shock DIN EN 60068-2-27	Operating: 15 G 11 ms duration / Storage: 30 G, 11 ms duration (half-sinus)	
Vibration DIN EN 60068-2-6	Operating: 10-500 Hz: 1 G / 3 axis / Storage: 10-500 Hz: 2 G / 3 axis	
Temperature / Humidity	Operating: 0°C to +50° / 20 to 85% non condensing / Storage: -20°C to +60° / 5 to 95% non condensing	
MTBF	> 40000 h (excluding the Backlight Tube)	
RoHS compliant	Yes	

Sold & Serviced By:

 **ELECTROMATE**

Toll Free Phone (877) SERV098

Toll Free Fax (877) SERV099

[www.electromate.com](http://www.electromate.com)

[sales@electromate.com](mailto:sales@electromate.com)

# Programmable Automation Controller (PAC)

## AKC-PNC-C1 Enhanced Performance

Technical Data	AKC-PNC-C1-224-100-00-000	AKC-PNC-C1-224-150-00-000
Display	10.0" TFT	15.0" TFT
Resolution	800 × 600	1024 × 768
Brightness	350cd / m <sup>2</sup>	250cd / m <sup>2</sup>
Touchscreen	Resistive analog	
Weight	ca. 7.9 kg	ca. 8.9 kg
Dimensions (H×W×D)	312 × 380 × 163 mm	354 × 450 × 163 mm
Processor	Celeron® 1.2 GHz	
RAM	2 GB	
Compact flash	4 GB	
NVRAM	128 k	
I/O standard	5x USB (1x front, 4x rear side), 1x LAN 10/100, 1x LAN 100/1000, 2x RS232, 1x DVI-I	
Free slots	2x PCI	
Power supply	24 Vdc	
Cooling	Fanless	
EMC	US:FCC47 CFR PART15; Class A level, CE:EN61000-6-2; EN55022/A (CISPR22)	
Certifications	CE, FCC, cULus	
Protection class	IP65 front (NEMA 250 Type 12 and 13)	
Altitude	Operating: 10000 ft (3.048 m), storage: 15000 ft (4.622 m)	
Shock DIN EN 60068-2-27	Operating: 15 G 11 ms duration / storage: 30 G, 11 ms duration (half-sinus)	
Vibration DIN EN 60068-2-6	Operating: 10-500 Hz: 1 G / 3 axis / storage: 10-500 Hz: 2 G / 3 axis	
Temperature / Humidity	Operating: 0°C to +50° / 20 to 85% non condensing / storage: -20°C to +60° / 5 to 95% non condensing	
MTBF	> 40000 h (excluding the backlight tube)	
RoHS compliant	Yes	



Standard

- Standard style PACs offer the flexibility of separating your HMI display from the controller unit. A variety of CPU choices along with substantial built-in RAM and NVRAM provide the right solution for your application.
- Our high-performance box PAC can be mated to a 19" rack mount unit to provide a rack mount PAC for those who prefer this configuration.

## AKC-PLC-C1, AKC-PLC-D2 and AKC-RMC-D2 High-Performance (no display)

Technical Data	AKC-PLC-C1-224-00N-00-000	AKC-PLC-D2-224-00N-00-000	AKC-RMC-D2-224-00N-00-000
Construction	Heavy duty steel		
Mounting	Wall mount, desktop	Wall mount, desktop	Rack mount
Control panel switch	Power on		
CPU	Intel® Celeron® 1.2 GHz	Intel® Dual Core 2.26 GHz	Intel® Dual Core 2.26 GHz
RAM	2 GB		
NVRAM	128 k		
Compact flash	4 GB		
I/O standard	2x USB 2.0, 2-4x RS232, 1x LPT, 2x PS/2		
Ethernet	1x LAN 10/100, 1x LAN 10/100/1000		
Expansion slots	2x PCI, PCMCIA optional		
Power supply	24 Vdc		
Cooling	Fanless cooling		
Certifications	CE, FCC A, cULus		
Shock IEC60068-2-27	Operating: 15 G, 11ms / storage: 30 G, 11 ms duration		
Vibration IEC 60068-2-6	Operating: 10-500 Hz, 1 G / 3 axis / storage: 10-500 Hz: 2 G / 3 axis		
Temperature / Humidity	Operating: 0° C to +50° C / 20 to 85% non condensing / storage: -20° C to +60° C / 5 to 95% non condensing		
MTBF	> 40000 h		
RoHS compliant	Yes		

# Human Machine Interface (HMI)

## AKI™ Interface

Kollmorgen Automation Suite's combination of easy-to-use, high-performance HMI development software and industrial grade HMI panels gives your machine unparalleled visualization capabilities. Great-looking displays that are easy to develop and implement in a rugged and reliable touch screen package.

Integrated Ethernet connectivity and program development from within the Kollmorgen Automation Suite software environment provides seamless set-up and operation.



## Typical AKI HMI Panel

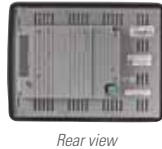

## AKI-CDT-MOD-04T

Hardware	
Display	TFT-LCD. 320 x 240 pixels, 64K colors. LED backlight lifetime at the ambient temperature of +25 °C: >10,000 h.
Screen size / Active display, W x H	3.5" / 70.1 x 52.6 mm
Front / Rear seal	IP 66 / IP 20
Touchscreen material	Touch screen: Polyester on glass, 1 million finger touch operations. Overlay: Autotex F157 / F207
Reverse side material	Powder-coated aluminum
Processor / RAM	416 MHz RISC CPU (Intel Xscale) / 64 MB
Flash memory	32 MB with 12 MB for applications and fonts
Real-time clock	±20 PPM + error because of ambient temperature. Total maximum error: 1 min/month at 25 °C Temperature coefficient: -0.034±0.006 ppm/°C2
Power consumption at rated voltage	Normal: 0.15 A, Maximum: 0.35 A
Fuse	Internal fuse, 2.0 AT, 5 x 20 mm
Power supply	+24 Vdc (20 - 30 Vdc), 3-pin jack connection block. CE: The power supply must conform with the requirements according to IEC 60950 and IEC 61558-2-4. UL and cUL: The power supply must conform with the requirements for class II power supplies.
Operating temperature	Vertical installation: 0 ° to +50 °C Horizontal installation: 0 ° to +40 °C
Storage temperature	-20 ° to +70 °C
Relative operating humidity	5 - 85 % non-condensed
Certificates and Approvals	
CE approvals	Noise tested according to EN61000-6-3 emission and EN61000-6-2 immunity.
UL, cUL approvals (when product or packing is marked)	UL 1604 Class I, Div 2 / UL 508 / UL 50 4x indoor use only
DNV	Yes
NEMA	4x indoor use only
Germanischer Lloyd	Yes
Communication	
Ethernet	10/100 Mbit/s. Shielded RJ 45
USB	Host type A (USB 1.1), max. output current 500 mA
Dimensions	
Front panel, W x H x D	155.8 x 119 x 6 mm
Cut out dimensions	139 x 105 mm
Mounting depth	57 mm (157 mm including clearance)
Weight	0.6 kg

# Human Machine Interface (HMI)

## AKI-CDT-MOD-06T

Hardware	
Display	TFT-LCD. 320 x 240 pixels, 64K colors. LED backlight lifetime at the ambient temperature of +25 °C: >20,000 h.
Screen size / Active display, W x H	5.7" / 115.2 x 86.4 mm
Front / rear seal	IP 66 / IP 20
Touchscreen material	Touch screen: Polyester on glass, 1 million finger touch operations. Overlay: Autotex F157/ F207
Reverse side material	Powder-coated aluminum
Processor / RAM	416 MHz RISC CPU (Intel Xscale) / 64 MB
Flash memory	32 MB with 12 MB for applications and fonts
Real-time clock	±20 PPM + error because of ambient temperature. Total maximum error: 1 min/month at 25 °C Temperature coefficient: -0.034±0.006 ppm/°C2
Power consumption at rated voltage	Normal: 0.25 A, Maximum: 0.45 A
Fuse	Internal fuse, 2.0 AT, 5 x 20 mm
Power supply	+24 Vdc (20 - 30 Vdc). 3-pin jack connection block. CE: The power supply must conform with the requirements according to IEC 60950 and IEC 61558-2-4. UL and cUL: The power supply must conform with the requirements for class II power supplies.
Operating temperature	Vertical installation: 0 ° to +50 °C Horizontal installation: 0 ° to +40 °C
Storage temperature	-20 ° to +70 °C
Relative operating humidity	5 - 85 % non-condensed
Certificates and Approvals	
CE approvals	Noise tested according to EN61000-6-3 emission and EN61000-6-2 immunity.
UL, cUL approvals (when product or packing is marked)	UL 1604 Class I, Div 2 / UL 508 / UL 50 4x indoor use only
DNV	Yes
NEMA	4x indoor use only
Germanischer Lloyd	Yes
Communication	
Ethernet	10/100 Mbit/s. Shielded RJ 45
USB	Host type A (USB 1.1), max. output current 500 mA
Dimensions	
Front panel, W x H x D	202 x 152 x 6 mm
Cut out dimensions	180 x 130 mm
Weight	0.9 kg

Sold & Serviced By:



Toll Free Phone (877) SERV098

Toll Free Fax (877) SERV099

[www.electromate.com](http://www.electromate.com)

[sales@electromate.com](mailto:sales@electromate.com)



**AKI-CDT-MOD-10T**

Hardware	
Display	TFT-LCD. 800 x 600 pixels, 64K colors. CCFL backlight lifetime at the ambient temperature of +25 °C: >50,000 h.
Screen size / Active display, W x H	10.4" / 211.2 x 158.4 mm
Front / Rear seal	IP 66 / IP 20
Touchscreen material	Touch screen: Polyester on glass, 1 million finger touch operations. Overlay: Autotex F157/ F207
Reverse side material	Powder-coated aluminum
Processor / RAM	520 MHz RISC CPU (Intel Xscale) / 64 MB
Flash memory	32 MB with 12 MB for applications and fonts
Real-time clock	±20 PPM + error because of ambient temperature. Total maximum error: 1 min/month at 25 °C Temperature coefficient: -0.034±0.006 ppm/°C2
Power consumption at rated voltage	Normal: 0.5 A, Maximum: 1.0 A
Fuse	Internal fuse, 2.0 AT, 5 x 20 mm
Power supply	+24 Vdc (20 - 30 Vdc), 3-pin jack connection block. CE: The power supply must conform with the requirements according to IEC 60950 and IEC 61558-2-4. UL and cUL: The power supply must conform with the requirements for class II power supplies.
Operating temperature	Vertical installation: 0 ° to +50 °C Horizontal installation: 0 ° to +40 °C
Storage temperature	-20 ° to +70 °C
Relative operating humidity	5 - 85 % non-condensed
Certificates and Approvals	
CE approvals	Noise tested according to EN61000-6-4 emission and EN61000-6-2 immunity.
UL, cUL approvals (when product or packing is marked)	UL 1604 Class I, Div 2 / UL 508 / UL 50 4x indoor use only
DNV	Yes
NEMA	4x indoor use only
Germanischer Lloyd	Yes
Communication	
Ethernet	10/100 Mbit/s. Shielded RJ 45
USB	Host type A (USB 1.1), max. output current 500 mA Device type B (USB 1.1)
Dimensions	
Front panel, W x H x D	302 x 228 x 6 mm
Cut out dimensions	265 x 206 mm
Mounting depth	58 mm (158 mm including clearance)
Weight	2.1 kg

Sold &amp; Serviced By:



Toll Free Phone (877) SERV098

Toll Free Fax (877) SERV099

www.electromate.com

sales@electromate.com

# Human Machine Interface (HMI)

## AKI-CDF-MOD-06T

Hardware	
Display	TFT-LCD. 320 x 240 pixels, 64K colors. LED backlight lifetime at the ambient temperature of +25 °C: >20,000 h.
Screen size / Active display, W x H	5.7" / 115.2 x 86.4 mm
Function keys	16 (8 with integrated LED and text strip)
LEDs	16 (8 with integrated LED and text strip)
Front / rear seal	IP 66 / IP 20
Keyboard material	Membrane switch keyboard with metal domes. Overlay film of Autotex F157 with print on reverse side. 1 million operations.
Reverse side material	Powder-coated aluminum
Processor / RAM	416 MHz RISC CPU (Intel Xscale) / 64 MB
Flash memory	32 MB with 12 MB for applications and fonts
Real-time clock	±20 PPM + error because of ambient temperature. Total maximum error: 1 min/month at 25 °C Temperature coefficient: -0.034±0.006 ppm/°C2
Power consumption at rated voltage	Normal: 0.25 A, Maximum: 0.45 A
Fuse	Internal fuse, 2.0 AT, 5 x 20 mm
Power supply	+24 Vdc (20 - 30 Vdc). 3-pin jack connection block. CE: The power supply must conform with the requirements according to IEC 60950 and IEC 61558-2-4. UL and cUL: The power supply must conform with the requirements for class II power supplies.
Operating temperature	Vertical installation: 0 ° to +50 °C Horizontal installation: 0 ° to +40 °C
Storage temperature	-20 ° to +70 °C
Relative operating humidity	5 - 85 % non-condensed
Certificates and Approvals	
CE approvals	Noise tested according to EN61000-6-3 emission and EN61000-6-2 immunity.
UL, cUL approvals (when product or packing is marked)	UL 1604 Class I, Div 2 / UL 508 / UL 50 4x indoor use only
DNV	Yes
NEMA	4x indoor use only
Germanischer Lloyd	Yes
Communication	
Serial port RS422/RS485	25-pin D-sub contact, female with standard locking screws 4-40 UNC.
Serial port RS232C	9-pin D-sub contact, male with standard locking screws 4-40 UNC.
Ethernet	10/100 Mbit/s. Shielded RJ 45
USB	Host type A (USB 1.1), max. output current 500 mA
Field buses (expansion modules)	Profibus DP slave
Dimensions	
Front panel, W x H x D	275 x 168 x 6 mm
Cut out dimensions	275 x 168 x 6 mm
Mounting depth	57 mm (157 mm including clearance)
Weight	1.2 kg

Sold & Serviced By:



Toll Free Phone (877) SERV098

Toll Free Fax (877) SERV099

[www.electromate.com](http://www.electromate.com)

[sales@electromate.com](mailto:sales@electromate.com)

**AKI-CDF-MOD-10T**

Hardware	
Display	TFT-LCD. 8000 x 6000 pixels, 64K colors. LED backlight lifetime at the ambient temperature of +25 ° C: >50,000 h.
Screen size / Active display, W x H	10.4" / 211.2 x 158.4 mm
Function keys	22 (10 with integrated LED and text strip)
LEDs	22 (10 with integrated LED and text strip)
Front / rear seal	IP 66 / IP 20
Keyboard material	Membrane switch keyboard with metal domes. Overlay film of Autotex F157 with print on reverse side. 1 million operations.
Reverse side material	Powder-coated aluminum
Processor / RAM	520 MHz RISC CPU (Intel Xscale) / 64 MB
Flash memory	32 MB with 12 MB for applications and fonts
Real-time clock	±20 PPM + error because of ambient temperature. Total maximum error: 1 min/month at 25 °C Temperature coefficient: -0.034±0.006 ppm/°C2
Power consumption at rated voltage	Normal: 0.5 A, Maximum: 1.0 A
Fuse	Internal fuse, 3.15 AT, 5 x 20 mm
Power supply	+24 Vdc (20 - 30 Vdc). 3-pin jack connection block. CE: The power supply must conform with the requirements according to IEC 60950 and IEC 61558-2-4. UL and cUL: The power supply must conform with the requirements for class II power supplies.
Operating temperature	Vertical installation: 0 ° to +50 ° C Horizontal installation: 0 ° to +40 ° C
Storage temperature	-20 ° to +70 ° C
Relative operating humidity	5 - 85 % non-condensed
Certificates and Approvals	
CE approvals	Noise tested according to EN61000-6-3 emission and EN61000-6-2 immunity.
UL, cUL approvals (when product or packing is marked)	UL 1604 Class I, Div 2 / UL 508 / UL 50 4x indoor use only
DNV	Yes
NEMA	4x indoor use only
Germanischer Lloyd	Yes
Communication	
Serial port RS422/RS485	25-pin D-sub contact, female with standard locking screws 4-40 UNC.
Serial port RS232C	9-pin D-sub contact, male with standard locking screws 4-40 UNC.
Ethernet	10/100 Mbit/s. Shielded RJ 45
USB	Host type A (USB 1.1), max. output current 500 mA
CF-Slot	Compact flash, type I and II
Field buses (expansion modules)	Profibus DP slave
Dimensions	
Front panel, W x H x D	382 x 252 x 6 mm
Cut out dimensions	343 x 208 mm
Mounting depth	58 mm (158 mm including clearance)
Weight	2.5 kg

Sold &amp; Serviced By:



Toll Free Phone (877) SERV098

Toll Free Fax (877) SERV099

www.electromate.com

sales@electromate.com

# Human Machine Interface (HMI)

## AKI-CDT-MOD-15T

Hardware	
Display	TFT-LCD. 1024 x 768 pixels, 64K colors. CCFL backlight lifetime at the ambient temperature of +25 ° C: >35,000 h.
Screen size / Active display, W x H	15.0" / 304.1 x 228.1 mm
Front / Rear seal	IP 66 / IP 20
Touchscreen material	Touch screen: Polyester on glass, 1 million finger touch operations. Overlay: Autotex F157/ F207.
Reverse side material	Powder-coated aluminum
Processor / RAM	520 MHz RISC CPU (Intel Xscale) / 64 MB
Flash memory	32 MB with 12 MB for applications and fonts
Real-time clock	±20 PPM + error because of ambient temperature. Total maximum error: 1 min/month at 25 °C Temperature coefficient: -0.034±0.006 ppm/°C2
Power consumption at rated voltage	Normal: 1.2 A, Maximum: 1.7 A
Fuse	Internal fuse, 3.15 AT, 5 x 20 mm
Power supply	+24 Vdc (20 - 30 Vdc). 3-pin jack connection block. CE: The power supply must conform with the requirements according to IEC 60950 and IEC 61558-2-4. UL and cUL: The power supply must conform with the requirements for class II power supplies.
Operating temperature	Vertical installation: 0 ° to +50 ° C Horizontal installation: 0 ° to +40 ° C
Storage temperature	-20 ° to +70 ° C
Relative operating humidity	5 - 85 % non-condensed
Certificates and Approvals	
CE approvals	Noise tested according to EN61000-6-4 emission and EN61000-6-2 immunity.
UL, cUL approvals (when product or packing is marked)	UL 1604 Class I, Div 2 / UL 508 / UL 50 4x indoor use only
DNV	Yes
NEMA	4x indoor use only
Germanischer Lloyd	Yes
Communication	
Ethernet	10/100 Mbit/s. Shielded RJ 45
USB	Host type A (USB 1.1), max. output current 500 mA Device type B (USB 1.1)
Dimensions	
Front panel, W x H x D	398 x 304 x 6 mm
Cut out dimensions	356 x 279 mm
Mounting depth	60 mm (160 mm including clearance)
Weight	3.7 kg

# I/O Terminal

## Advanced Kollmorgen Terminal (AKT)

The Kollmorgen Automation Suite includes an array of I/O options for applications that need more I/O than can be provided by the onboard I/O of the drives or for applications that need specialized functionality such as thermocouple management through I/O. The DIN rail mount IP20 terminals simply slide together and connect to the system's EtherCAT bus where they are auto-recognized for easy configuration.



I/O

### Typical Bus Coupler



EtherCAT bus coupler

### Typical I/O Terminal



Front wiring view



Side label view

Available Motion Bus Coupler Model	
AKT-ECT-000-000	EtherCAT Bus Coupler
Available Analog Input Terminal Models	
AKT-AN-410-000	4 channel analog input module, 0-10 Vdc
AKT-AN-420-000	4 channel analog input module, 0-20 ma
AKT-AN-810-000	8 channel analog input module, 0-10 Vdc
AKT-AN-820-000	8 channel analog input module, 0-20 ma
AKT-AN-200-000	2 channel thermocouple input module
AKT-AN-400-000	4 channel thermocouple input module
Available Analog Output Terminal Models	
AKT-AT-220-000	2 channel analog output module, 0-20 ma
AKT-AT-410-000	4 channel analog output module, 0-10 Vdc
AKT-AT-420-000	4 channel analog output module, 0-20 ma
AKT-AT-810-000	8 channel analog output module, 0-10 Vdc
AKT-AT-820-000	8 channel analog output module, 0-20 ma
Available Digital Output Terminal Models	
AKT-DT-004-000	4 channel digital output module, 0.5A
AKT-DT-008-000	8 channel digital output module, 0.5A
AKT-DT-2RT-000	2 channel relay output module, 2.0A, N/O
Available Digital Input Terminal Models	
AKT-DN-004-000	4 channel digital input module, 3ms
AKT-DNH-004-000	4 channel digital input module, .2ms
AKT-DN-008-000	8 channel digital input module, 3ms
AKT-DNH-008-000	8 channel digital input module, .2ms
Available Specialty Terminal Models	
AKT-EM-000-000	End module
AKT-IM-000-000	Isolation module
AKT-PS-024-000	Bus feed terminal, 24 Vdc
AKT-PSF-024-000	Bus feed terminal, 24 Vdc, fused
Available Field Bus Coupler Models	
AKT-PRB-000-000	Profibus Bus Coupler
AKT-ENP-000-000	Ethernet/IP Bus Coupler

Sold & Serviced By:

 **ELECTROMATE**

Toll Free Phone (877) SERV098

Toll Free Fax (877) SERV099

[www.electromate.com](http://www.electromate.com)

[sales@electromate.com](mailto:sales@electromate.com)

# Services

## Application Development, Start-up, Troubleshooting, and Training

The Kollmorgen Automation Suite portfolio offers extensive application development services and solutions development for the customer. Some of the key areas in which application engineering services are available include:

- Development and on-site deployment with IEC 61131-3, Pipe Network, PLCopen for motion, HMI, and motion control for standard motion and complex synchronized motion across many axes
- Knowledge transfer to help you maintain systems
- Helps reduce manpower investment for the initial efforts of machine building
- Ability to help you integrate your machine to the factory floor or your data to your ERP systems

These are available to our customers to leverage our experience, when necessary, with developing solutions. Start-up and troubleshooting services are available to ensure the rapid commissioning of new systems and to resolve unexpected issues that may arise with a new or established installation.

In addition, Kollmorgen offers wide-ranging training in many areas related to motion control and automation. Training can be either onsite or offsite and uses specialized demo kits for hands-on participation. Demo kits allow the trainee to see actual motion in action and receive real-time experience and feedback during the training program. The course can be taken online or in a classroom setting. Either way, the student can have access to a training kit that includes: A controller, AKD servo drives, I/O, and AKM servomotors in a single, compact unit.

Courses are available in the IEC 61131-3 languages, PLC solution architecture, HMI solution development, and motion control. On request, custom training courses are also offered to suit the specific needs of a given organization.

Sold & Serviced By:



Toll Free Phone (877) SERV098

Toll Free Fax (877) SERV099

[www.electromate.com](http://www.electromate.com)

[sales@electromate.com](mailto:sales@electromate.com)

On the Kollmorgen Automation Suite website, find extensive information about developing solution architectures. It provides the right level of information and is structured to prevent information overload. Complete, detailed data sheets and installation manuals for the various Kollmorgen Automation Suite products are available for download on the site.

In addition, personalize your experience with the MyKAS website - interact with Kollmorgen's product development, engineering, and marketing teams. This website can be used for:

- **Bug Reporting**

Reporting bugs and receiving direct support from the R&D and product management teams.

- **Dynamic FAQs (Frequently Asked Questions)**

Most static FAQs are a guesswork of what the systems development engineers may be interested in. The Kollmorgen FAQ evolves by looking at what the developer community needs. Questions that receive higher viewing bubble to the top to provide information on areas of customer concern. This also alerts Kollmorgen to aspects of the product which may need to be explained better. Such alerts result in benefit to the engineer as Kollmorgen can improve product documentation or create additional examples.

The community can also ask questions online and Kollmorgen's continuous improvement philosophy ensures that these questions are taken into account either for online response or for future product development.

- **Online Purchases**

Using PayPal™, purchase limited sets of items online for development and prototyping.



Learn about the product family and offerings

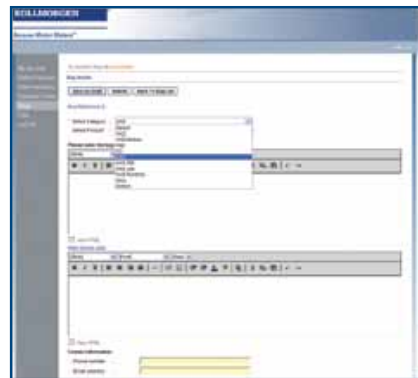

Rich text edit of bug report to product management and engineering. Workflow includes automatic email/follow-up request to product management and engineering management

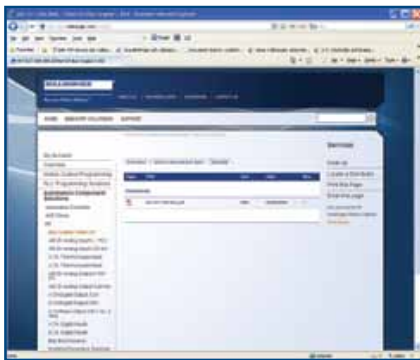

Review product specifications and download manuals and datasheets online

Sold & Serviced By:

 **ELECTROMATE**

Toll Free Phone (877) SERV098

Toll Free Fax (877) SERV099

www.electromate.com

sales@electromate.com

## Personalized Services

- Living FAQ that makes highly clicked questions bubble to the top
- Report bugs and review responses online
- Ask questions and review responses online
- Buy products with payments integrated by PayPal
- Download software using provided download codes
- Review past purchases and print receipts online



Discover Kollmorgen Automation Suite programming solution and approach



Make online purchase



Review our engineering and training services capabilities



View purchases



# Advanced Systems Creation

## Creating Your System with our Sales Representative

Our sales representatives bring more to the process of developing your unique system solution than just years of automation and motion control experience. Our new Kollmorgen System Designer tool lets them sit down with you and design the outline of your system on the spot.

- The System Designer tool contains a complete portfolio of Kollmorgen Automation Suite products from PACs for control right down to the cables that connect the system elements together. Because the components are pre-certified, your choices are always validated to create known systems where the components have been designed to work together in an optimal fashion.
- Simply diagram the system by dragging and dropping components onto an application palette. Connect these components using cables that are certified in the system. It is almost impossible to make a wrong connection.
- Once the parts and part numbers have been selected, the sales representative can generate a bill of materials for your review and even generate a standardized proposal for your system.
- The focus of work activities is not on the drawing process but capturing your requirements effectively to develop the right automation and motion control system architecture.

## System Designer Tool

- Template application wizard
- All Kollmorgen Automation Suite-enabled components
- Part number selection
- System interconnections

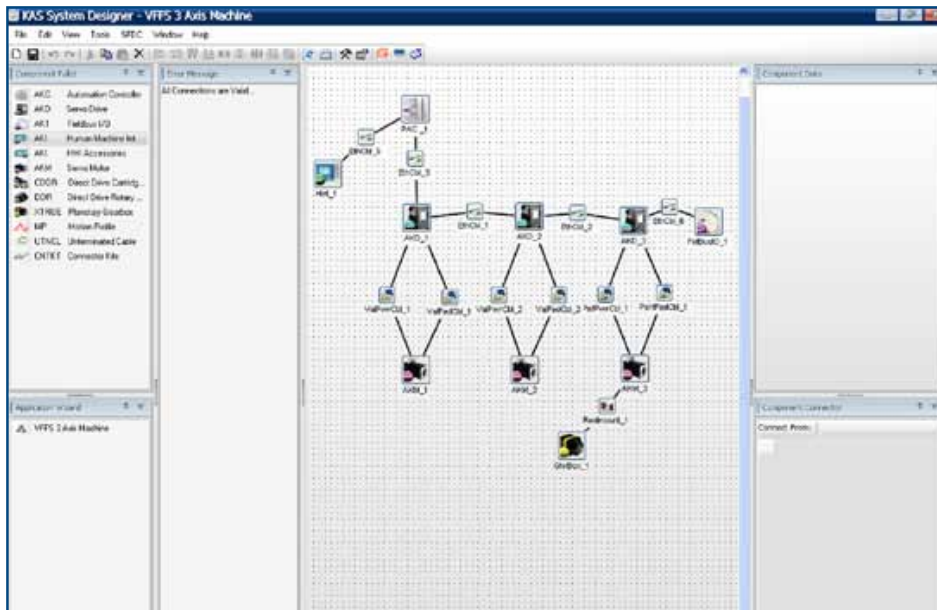

Sold & Serviced By:

 **ELECTROMATE**

Toll Free Phone (877) SERV098

Toll Free Fax (877) SERV099

[www.electromate.com](http://www.electromate.com)

[sales@electromate.com](mailto:sales@electromate.com)

# AKD™ Servo Drive

**Our AKD series is a complete range of Ethernet-based servo drives that are fast, feature-rich, flexible and integrate quickly and easily into any application.\*** AKD ensures plug-and-play commissioning for instant, seamless access to everything in your machine. And, no matter what your application demands, AKD offers industry-leading servo performance, communication options, and power levels, all in a smaller footprint.

This robust, technologically advanced family of drives delivers optimized performance when paired with our best-in-class components, producing higher quality results at greater speeds and more uptime. With Kollmorgen servo components, we can help you increase your machine's overall effectiveness by 50%.

\* Patents pending.

Sold & Serviced By:

 **ELECTROMATE**

Toll Free Phone (877) SERV098

Toll Free Fax (877) SERV099

[www.electromate.com](http://www.electromate.com)

[sales@electromate.com](mailto:sales@electromate.com)

## The Benefits of AKD Servo Drive

- Optimized Performance in Seconds
  - Auto-tuning is one of the best and fastest in the industry
  - Automatically adjusts all gains, including observers
  - Immediate and adaptive response to dynamic loads
  - Precise control of all motor types
  - Compensation for stiff and compliant transmission and couplings
- Greater Throughput and Accuracy
  - Up to 27-bit-resolution feedback yields unmatched precision and excellent repeatability
  - Very fast settling times result from a powerful dual processor system that executes industry-leading and patent pending servo algorithms with high resolution
  - Advanced servo techniques such as high-order observer and bi-quad filters yield industry-leading machine performance
  - Highest bandwidth torque-and-velocity loops. Fastest digital current loop in the market
- Easy-to-Use Graphical User Interface (GUI) for Faster Commissioning and Troubleshooting
  - Six-channel real-time software oscilloscope commissions and diagnoses quickly
  - Multi-function Bode Plot allows users to quickly evaluate performance
  - Auto-complete of programmable commands saves looking up parameter names
  - One-click capture and sharing of program plots and parameter settings allow you to send machine performance data instantly
  - Widest range of programming options in the industry
- Flexible and Scalable to Meet Any Application
  - 3 to 24 Arms continuous current; 9 to 48 Arms peak
  - Very high power density enables an extremely small package
  - True plug-and-play with all standard Kollmorgen servomotors and positioners
  - Supports a variety of single and multi-turn feedback devices—Smart Feedback Device (SFD), EnDat2.2, 01, BiSS, analog Sine/Cos encoder, incremental encoder, HIPERFACE®, and resolver
  - Tightly integrated Ethernet motion buses without the need to add large hardware: EtherCAT®, SynqNet®, Modbus/TCP, EtherNet/IP, PROFINET, and CANopen®
  - Scalable programmability from base torque-and-velocity through multi-axis master

Sold & Serviced By:

 **ELECTROMATE**

Toll Free Phone (877) SERV098

Toll Free Fax (877) SERV099

[www.electromate.com](http://www.electromate.com)

[sales@electromate.com](mailto:sales@electromate.com)

# AKD Servo Drive

AKD SERVO DRIVE

The AKD servo drive delivers cutting-edge technology and performance with one of the most compact footprints in the industry. These feature-rich drives provide a solution for nearly any application, from basic torque-and-velocity applications, to indexing, to multi-axis programmable motion with embedded Kollmorgen Automation Suite. The versatile AKD sets the standard for power density and performance.



Micron™ Gearheads

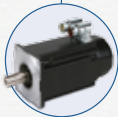

AKM™ Servomotors



Kollmorgen Cartridge DDR™ Motors



Housed Direct Drive Rotary Motors

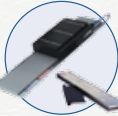

Direct Drive Linear Motors\*



Linear Positioners



Multi-Axis Precision Tables

## Best-in-Class Components

AKD works seamlessly with Kollmorgen motors and positioners—well-known for quality, reliability, and performance.



AKD™ Servo Drive

\* For more information on our direct drive linear motors, visit [www.kollmorgen.com/brushlessddl](http://www.kollmorgen.com/brushlessddl)

Sold & Serviced By:

 **ELECTROMATE**

Toll Free Phone (877) SERV098

Toll Free Fax (877) SERV099

[www.electromate.com](http://www.electromate.com)

[sales@electromate.com](mailto:sales@electromate.com)

# AKD Servo Drive Range of Coverage

When you pair the AKD servo drive with any of our Kollmorgen motors or linear positioners, you'll achieve optimized performance. From 3 to 24 Arms continuous current and 9 to 48 Arms peak current, the feature-rich AKD provides a solution for nearly any application.

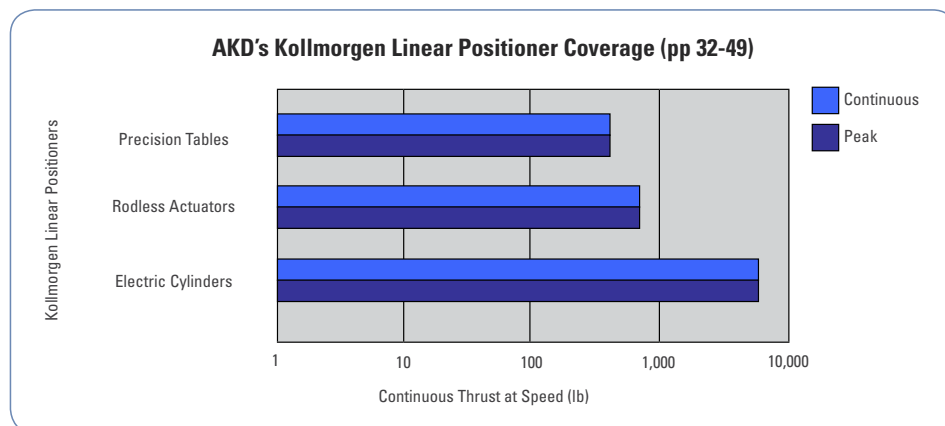
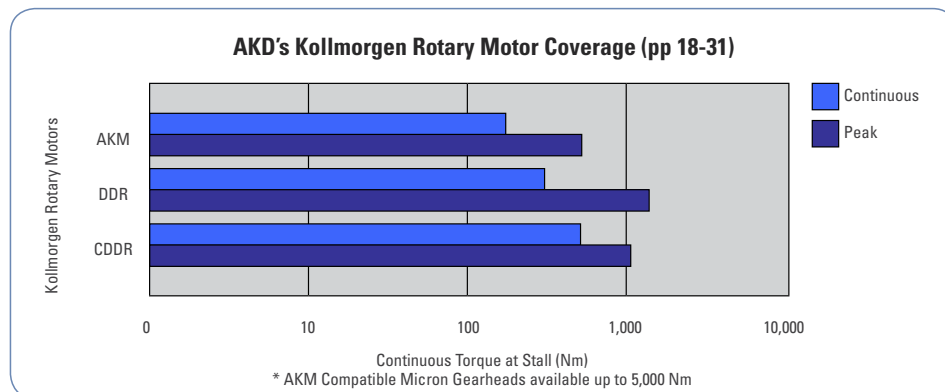
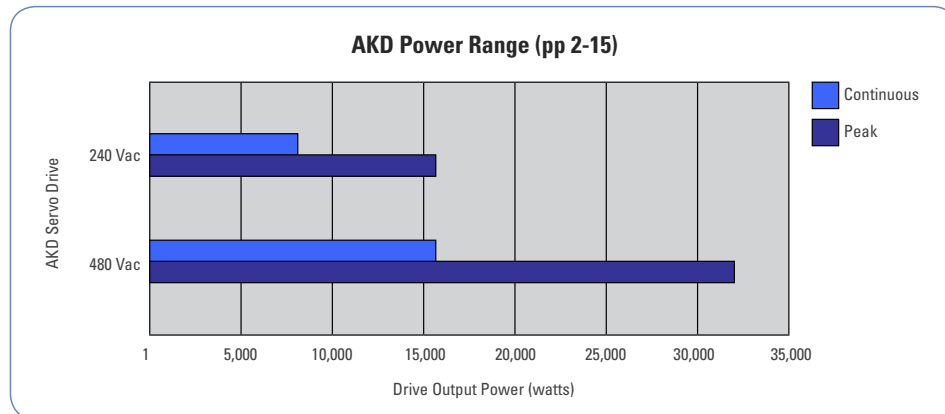

# AKD Servo Drive

AKD  
SERVO  
DRIVE

AKD servo drive is specifically designed with the versatility, communications, and power you need to expand machine performance and increase integration speeds. Motor set-up is plug-and-play and multiple Ethernet connectivity options provide both open and closed protocols. Online troubleshooting and data verification enable faster, bug-proof programming. And a broad power range in a smaller, compact design allows you to use these robust drives with a single interface while experiencing industry-leading, high-performance servo loops.

AKD Specifications		
Encoder Output or AUX Encoder Input	2.5 MHz Maximum line frequency	
Feedback	Smart Feedback Device (SFD), EnDat2.2, 01, BiSS, analog Sine/Cos encoder, incremental encoder, HIPERFACE®, and resolver	
Logic supply	24 Vdc	
	Base drive	With I/O expansion
Digital input (24 Vdc)	8 (1 dedicated to enable)	20 (1 dedicated to enable)
Digital output (24 Vdc)	3 (1 dedicated to fault relay)	13 (1 dedicated to fault relay)
Analog input (+/- 10 Vdc, 16-bit)	1	2
Analog output (+/- 10 Vdc, 16-bit)	1	2
Programmable inputs	7	19
Programmable outputs	2	12
Sink/Source inputs/outputs	Yes	Yes

Sold & Serviced By:



Toll Free Phone (877) SERV098

Toll Free Fax (877) SERV099

[www.electromate.com](http://www.electromate.com)

[sales@electromate.com](mailto:sales@electromate.com)



Industry-leading power density

### General Specifications

120 / 240 Vac 1 & 3 Phase (85 - 265 V)	Continuous Current (Arms)	Peak Current (Arms)	Drive Continuous Output Power Capacity (Watts)	Internal Regen (Watts) (Ohms)		Height mm (in)	Width mm (in)	Depth mm (in)	Depth with Cable Bend Radius mm (in)
AKD-■00306	3	9	1100	0	0	168 (6.61)	57 (2.24)	153 (6.02)	184 (7.24)
AKD-■00606	6	18	2000	0	0	168 (6.61)	57 (2.24)	153 (6.02)	184 (7.24)
AKD-■01206	12	30	4000	100	15	195 (7.68)	76 (2.99)	186 (7.32)	215 (8.46)
AKD-■02406	24	48	8000	200	8	250 (9.84)	100 (3.94)	230 (9.06)	265 (10.43)
240/480 Vac 3 Phase (187-528 V)	Continuous Current (Arms)	Peak Current (Arms)	Drive Continuous Output Power Capacity (Watts)	Internal Regen (Watts) (Ohms)		Height mm (in)	Width mm (in)	Depth mm (in)	Depth with Cable Bend Radius mm (in)
AKD-■00307	3	9	2000	100	33	256 (10.08)	70 (2.76)	186 (7.32)	221 (8.70)
AKD-■00607	6	18	4000	100	33	256 (10.08)	70 (2.76)	186 (7.32)	221 (8.70)
AKD-■01207	12	30	8000	100	33	256 (10.08)	70 (2.76)	186 (7.32)	221 (8.70)
AKD-■02407	24	48	16,000	200	23	310 (12.20)	105 (4.13)	229 (9.02)	264 (10.39)
AKD-■04807	48	96	32,000	400		<i>Coming in 2012</i>			
AKD-■09607	96	192	64,000	800		<i>Coming in 2012</i>			

Note: For complete AKD model nomenclature, refer to page 67

# Scalable Programmability

AKD SERVO DRIVE

The AKD servo drive delivers cutting-edge technology and performance with one of the most compact footprints in the industry. The AKD is flexible enough for virtually any application. From one axis that is as simple as analog torque and velocity, to 128 axes of fully programmable synchronized motion, AKD is the answer.

## Benefits

- Optimized performance in seconds
- Greater throughput and accuracy
- Easy-to-use Graphical User Interface (GUI) for faster commissioning and troubleshooting
- Flexible and scalable to meet any application



### Motion Tasking ("P" Option)

- Adds simple point-and-click indexing to base drive
- Provides user with pre-programmed options
- Guides novice user through simplified steps to create indexing moves
- Includes access to 11 digital I/O and 2 analog I/O on base drive
- Includes 2 high-speed digital inputs
- Expandable to 31 digital I/O and 4 analog I/O
- Same package size as base drive



### BASIC Programmable 1.5 Axis Drive ("T" Option)

- Adds BASIC programmability to base AKD
- 4Khz programmable interrupt service routines
- Conditional statements, built-in math functions, user functions and subroutines
- Includes access to 11 digital I/O and 2 analog I/O on base drive
- Includes 2 high-speed digital inputs
- Expandable to 31 digital I/O and 4 analog I/O
- Same package size as base drive

### Base AKD ("B" Option)

- Controlled by analog torque-and-velocity commands
- Includes electronic gearing via X9 connector
- Includes access to 11 digital I/O and 2 analog I/O on base drive
- Includes 2 high-speed digital inputs
- Expandable to 31 digital I/O and 4 analog I/O

Basic Operation

Single-Axis

Sold & Serviced By:

 **ELECTROMATE**

Toll Free Phone (877) SERV098

Toll Free Fax (877) SERV099

www.electromate.com

sales@electromate.com



# RANGE OF KOLLMORGEN AUTOMATION SUITE CAPABILITIES

AKD SERVO DRIVE



## AKD PDMM used standalone as a single-axis drive with integrated controller and soft-PLC

- Includes all the capabilities of Kollmorgen Automation Suite™ – a fully integrated, truly scalable programming solution
- Choose from all five IEC 61131-3 languages (structured text, function block diagram, ladder diagram, instruction list, sequential function chart) for soft PLC process programming
- Program motion using your choice of PLCopen for motion or our innovative Pipe Network™
- Exclusive function blocks, such as “wait,” enable your program to act as a scanning or sequential language
- Onboard I/O includes 17 digital (with 2 high-speed inputs) and 2 analog
- Controls AKT™ remote I/O for nearly unlimited expandability
- AKD PDMM only adds 30mm width to AKD base drives

## Seamlessly add additional axes and AKD PDMM serves as a high-performance multi-axis machine controller

- Provide true synchronized-path control of up to 8 or more axes
- Reduce cabinet size and wiring requirements with onboard motion and machine control in a single, compact package
- Easily manage remote I/O and the I/O of all attached drives via EtherCAT
- Use PLCopen for motion or Pipe Network™ to program sophisticated camming and gearing applications in a matter of minutes
- Add 11 digital and 2 analog I/O to the system with each additional AKD Servo axis incorporated
- Includes 2 high-speed digital inputs for each additional AKD servo axis

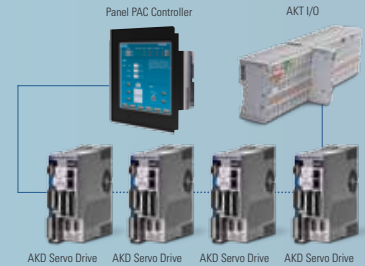

## Kollmorgen Automation Suite Programmable Automation Controller (PAC)

- Build EtherCAT-based systems up to 128 axes of high-performance motion using a PAC controller
- This scalable solution provides a full integrated development environment for any application, whether programming a single axis of motion, a multi-axis AKD PDMM™ system, or a PAC-based system up to 128 axes
- Panel PACs include the choice of a 10”, 15” or 17” touchscreen user interface
- PAC controllers include choice of Celeron or Core2Duo processor for scalable performance
- Program camming, gearing and other motion applications using a choice of PLC open for motion or the graphical Pipe Network™
- Add 11 digital and 2 analog I/O to the system with each additional AKD Servo axis incorporated
- Includes 2 high-speed digital inputs for each additional AKD servo axis

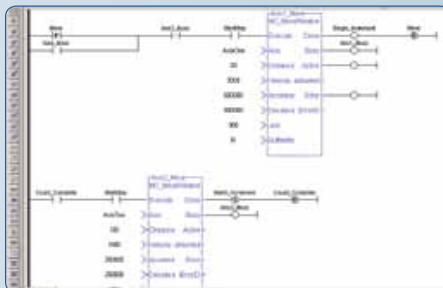

IEC 61131-3 with five languages for process programming (soft PLC)

Choice of PLCopen for motion or Kollmorgen exclusive Pipe Network for motion programming

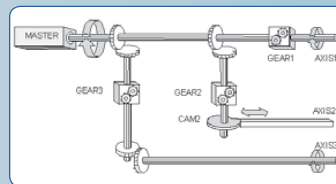

Using the exclusive Pipe Network provides a one-to-one translation of a mechanical system into a logical world.

## Programming

## Multi-Axis Programming

Sold & Serviced By:

**ELECTROMATE**

Toll Free Phone (877) SERV098

Toll Free Fax (877) SERV099

www.electromate.com

sales@electromate.com

# AKD BASIC Drives

AKD  
SERVO  
DRIVE

## High Performance Capabilities in an Integrated Drive/Control Solution

Add co-engineering to your toolbox. Save money, simplify your machine and customize performance to meet the specific needs of each customer or application – as needed, today or tomorrow.

Our new Kollmorgen AKD™ BASIC drives add BASIC-programmable machine and motion control to the superior performance of our AKD drive platform. So engineers can quickly customize performance at the drive level without touching the PLC. In fact, for many applications you can avoid the expense, wiring and cabinet space of a PLC altogether.

Whether you rely on your own engineering expertise or Kollmorgen's, the base and Expanded I/O versions of our AKD BASIC drive give you the unprecedented machine and motion control flexibility in a compact, fully integrated drive package. It's one more example of our co-engineering mission to help you deliver exactly what your customers want – when they want it – in solutions that are more cost-effective to build, simpler in design and faster to market.

### AKD BASIC Language Programmable Drive

In addition to the wide selection and key features of our proven AKD, the standard version of our AKD BASIC drive offers:

- **Programmable machine control built into the drive**, so you can engineer perfect axis-level performance without touching the machine controller. In fact, AKD BASIC can eliminate the need for a PLC in single and 1.5 axis applications – reducing wiring requirements, panel space, design complexity and cost.
- **High performance motion control built into the drive**, enabling increased speed for more complex moves in a simpler design with reduced wiring.
- **BASIC Language programming**, providing simple program flow control in a solution that's easy to learn, quick to master and universally accepted.
- **An integrated development environment**, allowing single-point programming, de-bugging, commissioning, tuning and management of your AKD BASIC drive from within AKD WorkBench. Our BASIC editor provides innovative features that speed development time and reduce coding errors.
- **Source code lockout with password protection**, freeing you to differentiate your product with drive-level control while safeguarding your intellectual property.

I/O Capabilities	Base Version	Expanded I/O Version
Digital Inputs	8	20
Digital Outputs	3	13
Analog Inputs	1	2
Analog Outputs	1	2

### Expanded I/O AKD BASIC Programmable Drive

Building on the features of the AKD BASIC drive, we also offer an expanded I/O version that adds:

- **A total of 20 digital inputs, 13 digital outputs, 2 analog inputs and 2 analog outputs**, reducing or eliminating the need for remote I/O and its associated installation and wiring costs.
- **An SD memory card slot** for loading, and restoring programs and parameters, without the need for a PC.



Sold & Serviced By:

 **ELECTROMATE**

Toll Free Phone (877) SERV098

Toll Free Fax (877) SERV099

[www.electromate.com](http://www.electromate.com)

[sales@electromate.com](mailto:sales@electromate.com)

# Development Tools that Speed Programming and Improve Quality

Co-engineering is a powerful tool. To make it easy for you to provide better solutions for your customers, we provide an innovative BASIC programming environment within Kollmorgen WorkBench. So there's only one software package to use for all of your drive setup, configuration, tuning and management tasks in addition to motion and machine control programming.

Pre-built code templates give your application a head-start, while automatic formatting, highlighting and other ease-of-use features increase programming speed and accuracy. Complete access to all programming capabilities and drive features within a single environment helps speed your development of complete, optimally engineered solutions.

Novice users will enjoy a short ramp-up time to productive coding, while experienced users will discover well-designed tools that take their programming skills to new levels of speed and quality.

- 1 Integrated axis setup
- 2 Code snippets simplify formatting
- 3 Auto-complete helps speed coding and reduce errors
- 4 Automatic color coding makes it easy to distinguish comments, parameters, print statements and other types of code
- 5 Full debugger accelerates development
- 6 Packaged program console provides instant program status
- 7 Menu-driven navigation provides intuitive look and feel
- 8 Window pinning maximizes workspace

The screenshot displays the Kollmorgen WorkBench software interface. The main window is titled "Program" and contains a BASIC program for a servo drive. The program code is as follows:

```

regmove loc X Reg_Move loc 1
Main
  * This is the PE for an absolute move reg
  * top of main loop
  while 1 = 1
  * THIS IS THE PE FOR AN ABSOLUTE MOVE REG
  IF (REG_STATE = 1) THEN 'registration move as an absolute move
  print "Input 3 triggered"
  Intr_REGENH = 1
  * HERE
  Move_PosCommand = 0
  * HERE
  * Move_Units
  * HERE
  Move_Acc = 1000' Acceleration (drive units)
  
```

The interface includes a "Device Topology" tree on the left (1), a "Program" editor with a toolbar (7) and a "Debugger" menu (5) on the right. The "Debugger" menu options are: Step Into (F8), Step Over (F10), Step Out (Shift-F11), Toggle Breakpoint (F7), Delete All Breakpoints, Enable All Breakpoints, and Disable All Breakpoints. A "Console" window (6) at the bottom shows the program's execution status, including "Starting Demo Program" and a list of control instructions (CIN 1-6). A "Code Snippets" window (2) is also visible, showing a snippet for "result = 2+3" with options like "Add", "Increment", "DecrementAndMultiply", "return", and "var".

Sold & Serviced By:

**ELECTROMATE**

Toll Free Phone (877) SERV098

Toll Free Fax (877) SERV099

www.electromate.com

sales@electromate.com

# AKD PDMM™ Integrated Servo Drive and Automation Controller

## Build Simpler and Better with Drive-Resident Machine and Motion Control

Extend your design options. Control as many as eight axes or more without the need for a PLC or PAC. Reduce cabinet space and wiring requirements. Program perfect machine and motion control for any project using a single, fully integrated programming environment. Build a better machine at a lower cost.

Our new addition to the AKD™ drive family combines one servo axis, a master controller that supports multiple additional axes, and the full automation capability of Kollmorgen Automation Suite™ (refer to page K4 for more information on Kollmorgen Automation Suite).—all in a single, compact package.

Welcome to the AKD PDMM™ programmable drive, multi-axis master.

### Performance Specifications

120/240 VAC 1- and 3-Phase	Continuous Current (Arms)	Peak Current (Arms)	H (mm/inches)	W (mm/inches)	D (mm/inches)
AKD-M00306-MCEC-0000	3	9	168 / 6.61	89 / 3.50	156 / 6.14
AKD-M00606-MCEC-0000	6	18	168 / 6.61	89 / 3.50	156 / 6.14
AKD-M01206-MCEC-0000	12	30	196 / 7.72	107 / 4.22	187 / 7.36
240/400/480 VAC 3-Phase	Continuous Current (Arms)	Peak Current (Arms)	H (mm/inches)	W (mm/inches)	D (mm/inches)
AKD-M00307-MCEC-0000	3	9	256 / 10.08	99 / 3.90	185 / 7.28
AKD-M00607-MCEC-0000	6	18	256 / 10.08	99 / 3.90	185 / 7.28
AKD-M01207-MCEC-0000	12	30	256 / 10.08	99 / 3.90	185 / 7.28



### Features

- Kollmorgen Automation Suite™ provides fully integrated programming, testing, setup and commissioning
- Embedded web server utility simplifies service
- Control 8 axes or more\* while reducing machine footprint
  - EtherCAT multi-axis master motion controller integrated with a standard AKD™ drive axis
  - Full IEC61131-3 soft PLC for machine control, with support for all 5 programming languages
  - Choice of PLCopen for motion or Pipe Network™ for programming motion control
  - 32 kB non-volatile memory stores machine data to eliminate scrap upon restart after power failure
  - SD Card slot simplifies backup and commissioning, with no PC required
  - Onboard I/O includes 13 digital inputs, 4 digital outputs, 1 analog input, 1 analog output (expandable with AKT series of remote I/O) (refer to page K19 for information on AKT I/O)
- Works with Kollmorgen Visualization Builder for programming AKI human-machine interface panels (refer to page K10 for more information on Kollmorgen Visualization Builder)

Sold & Serviced By:

 **ELECTROMATE**

Toll Free Phone (877) SERV098

Toll Free Fax (877) SERV099

[www.electromate.com](http://www.electromate.com)

[sales@electromate.com](mailto:sales@electromate.com)

## A Single, Scalable Development Suite

Kollmorgen Automation Suite™ simplifies and accelerates development through a unified system of software, hardware, and collaborative co-engineering. This scalable solution provides a fully integrated development environment for any application, whether you're programming a single axis of motion, a multi-axis AKD PDMM™ system, or a PAC-based system up to 128 axes. Kollmorgen Automation Suite has been proven to: (refer to page K11 for information on AKC PAC products)

- Improve product throughput by up to 25% with industry-leading motion bandwidth
- Reduce scrap by up to 50% with world-class servo accuracy, seamless power-failure recovery and highly dynamic changeovers
- Increase precision for better quality, reduced waste and less downtime using EtherCAT—the field bus with motion bus performance
- Enable more adaptable, sustainable and innovative machines that measurably improve marketability and profitability

### A Single Family of Servo Drives

Kollmorgen AKD™ servo drives deliver cutting-edge performance in a compact footprint. From basic torque-and-velocity applications, to indexing, to multi-axis programmable motion, these feature-rich drives offer:

- Plug-and-play compatibility with your servomotor
- All the advantages of Kollmorgen's breadth of motor platforms including AKM™, CDDR™, and other direct-drive technologies
- The fastest velocity and position loop updates
- Full-frequency autotuning for perfect motion across the performance spectrum
- Real-time feedback from a wide variety of devices

### Our Best Drive and Automation Solution in a Single Package

The new AKD PDMM programmable drive, multi-axis master combines our AKD drive platform with the full feature set of Kollmorgen Automation Suite in a single package—providing complete machine and motion control for up to eight axes or more.

You need only one development suite and one drive family for all your projects. And you can rely on one source for all the motion components and co-engineering expertise you need to build a better machine.

With AKD PDMM, the best in machine engineering has never been easier, faster or more cost-effective.

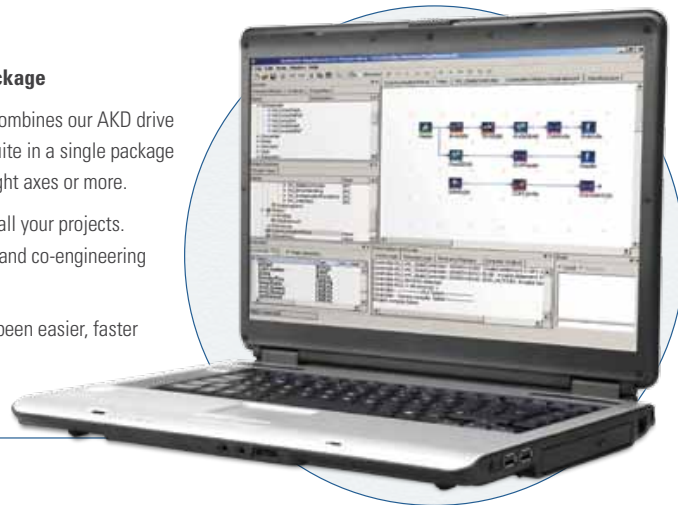

Sold & Serviced By:

 **ELECTROMATE**

Toll Free Phone (877) SERV098

Toll Free Fax (877) SERV099

[www.electromate.com](http://www.electromate.com)

[sales@electromate.com](mailto:sales@electromate.com)

# Kollmorgen WorkBench

Our simple Graphical User Interface (GUI), Kollmorgen WorkBench, is designed to expedite and streamline the user's experience with the AKD servo drive. From easy application selection and reduced math, to a sleek six-channel scope; the user interface is extremely easy to use. Kollmorgen WorkBench supports intuitive access to the exclusive Performance Servo Tuner (PST) available inside AKD. The patent pending PST makes auto-tuning the AKD high-performance servo drive with world-class Kollmorgen motors very simple.

## User-Friendly Environment

Logical flow, colorful icons and easy access simplify interactions with the AKD servo drive. The folder structure allows for instant identification and easy navigation.

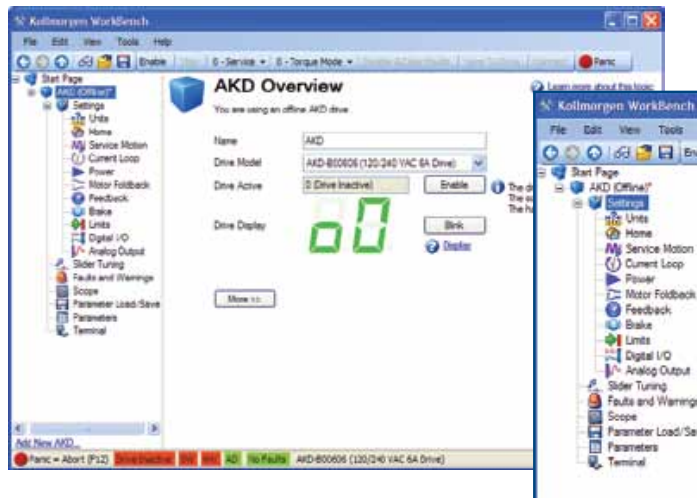

## Sleek Six-Channel "Real-Time" Software Oscilloscope

The easy-to-use AKD servo drive interface has a sleek digital oscilloscope that provides a comfortable environment for users to monitor performance. There are multiple options to share data in the format you prefer at the click of a button.

- Save as an image
- Load to an e-mail
- Print

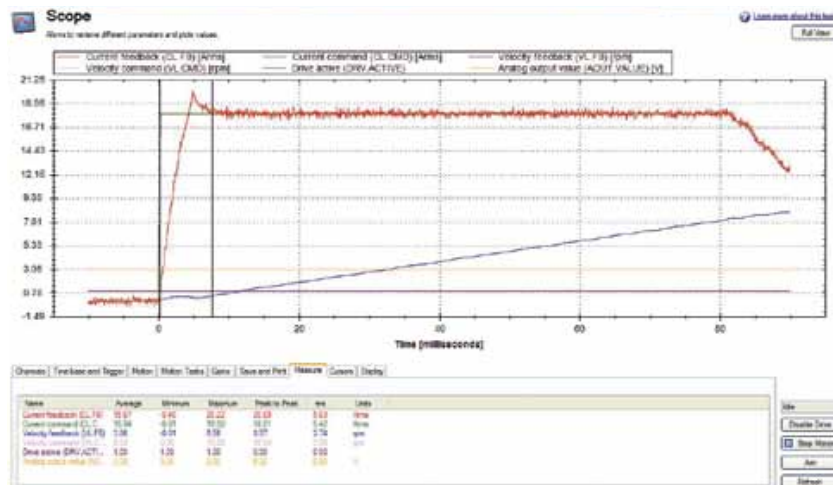

Sold & Serviced By:

**ELECTROMATE**

Toll Free Phone (877) SERV098

Toll Free Fax (877) SERV099

www.electromate.com

sales@electromate.com

## Application Selection

Simplifies set-up by allowing use of machine or application-based units. Nip roller and rack and pinion set-ups shown.

### Nip Roller Application Selection

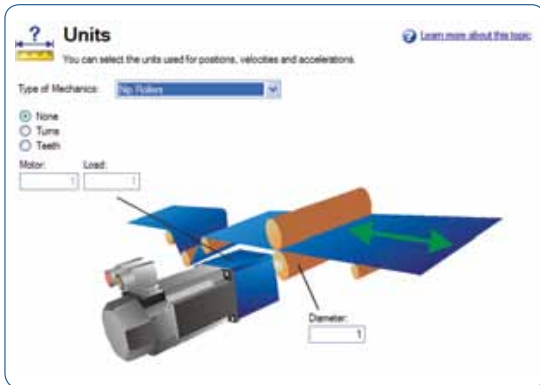

### Rack and Pinion Application Selection

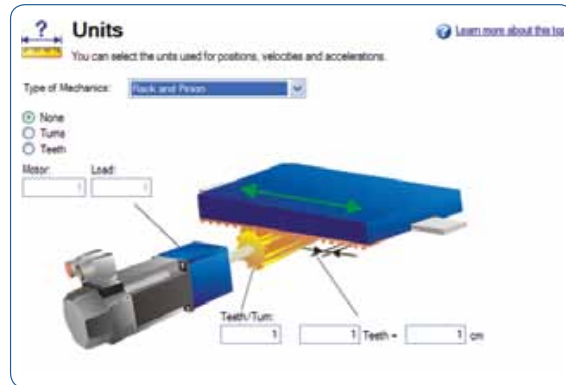

## Data-Sharing

The ease-of-sharing continues in the parameters window. Kollmorgen WorkBench provides the user the easy options of printing or emailing the parameter values at the click of a button.

Full Name	Value	Units	Parameter	Read/Write
<b>Active Disable</b>				
Deceleration during active disable	3000.000	rpm/s	AD DEC	read-write
Time-out	1000	ms	AD DISTO	read-write
State	0	ms	AD STATE	read-only
Velocity window	120.000	rpm	AD VELTHRESH	read-write
Time delay after velocity window	5	ms	AD VELTHRESHTM	read-write
<b>Analog Input</b>				
Analog input low pass filter cutoff freq.	5.000.000	Hz	AIN CUTOFF	read-write
Analog input signal deadband	0.000	V	AIN DEADBAND	read-write
Analog input mode	0 - Inactive		AIN MODE	read-write
Analog input offset	0.000	V	AIN OFFSET	read-write
Analog input signal	0.000	V	AIN VALUE	read-only
<b>Analog Input/Output</b>				
Analog input torque scale	0.001	AV	AIO ISCALE	read-write
Analog input velocity scale	0.060	rpm/V	AIO VSCALE	read-write
<b>Analog Output</b>				
Analog output mode	0 - User Variable		AOUT MODE	read-write
Analog output value	0.000	V	AOUT VALUE	read-only
<b>Mode</b>				
<b>Current Loop</b>				
Current command	0.000	A	CL CMD	read-only
Current command - user	0.000	A	CL CMDU	read-write
Current command - D component	0.000	A	CL DCMD	read-only
Current command - user D component	0.000	A	CL DCMDU	read-write

# AKD Connector Layout and Functionality

## Ethernet Connectivity

- Ethernet-based AKD servo drive provides the user with multiple bus choices
- EtherCAT® (DSP402 protocol), Modbus/TCP, SynqNet®, EtherNet/IP, PROFINET and CANopen®
- No option cards are required



## Industrial Design

- Rugged circuit design and compact enclosure for space-saving, modern appearance – minimizes electrical noise emission and susceptibility
- Full fault protection
- UL, cUL listed, and CE
- No external line filters needed (480 Vac units) for CE & UL compliance
- Removable screw terminal connectors for easy connections
- DC Bus sharing



## Safe-Torque-Off (STO)

(IEC 61800 SIL2)

- Switches off the power stage to ensure personnel safety and prevents an unintended restart of the drive, even in fault condition
- Allows logic and communication to remain on during power stage shut down

## Plug-and-Play with Kollmorgen Motors and Positioners

- Electronic motor nameplates allow parameters to automatically load for fast commissioning
- Motion in seconds
- Custom motor parameters easily entered

## Internal Regenerative Braking Resistor

(All powers except 120/240 Vac 3 Arms and 6 Arms)

- Simplifies system components
- Saves overhead of managing external regeneration when internal regeneration is sufficient

## I/O (Base Drive)

- 8 digital inputs (1 dedicated to enable)
- 2 high-speed digital inputs (maximum time delay of 1.0  $\mu$ s)
- 3 digital outputs (1 dedicated to fault relay)
- 1 analog input - 16 bit
- 1 analog output - 16 bit



## Performance Servo Tuner (PST)

- Exclusive patent pending auto-tuner reaches optimized set-up in seconds
- Handles inertia mismatches up to 1000:1
- Industry leading bandwidth under compliant and stiff load conditions, no matter the mechanical bandwidth of the machine



Sold & Serviced By:

**ELECTROMATE**

Toll Free Phone (877) SERV098

Toll Free Fax (877) SERV099

www.electromate.com

sales@electromate.com



### AKD 120/240 Vac Connector Layout

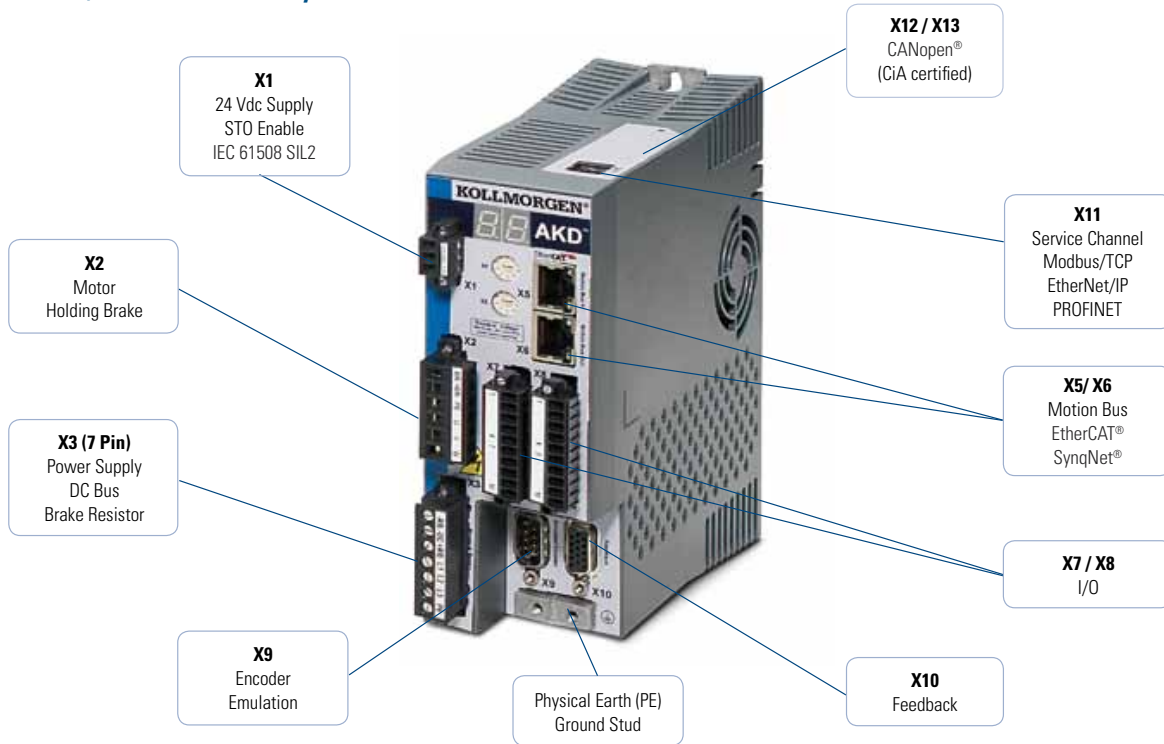

### AKD 240/480 Vac Connector Layout

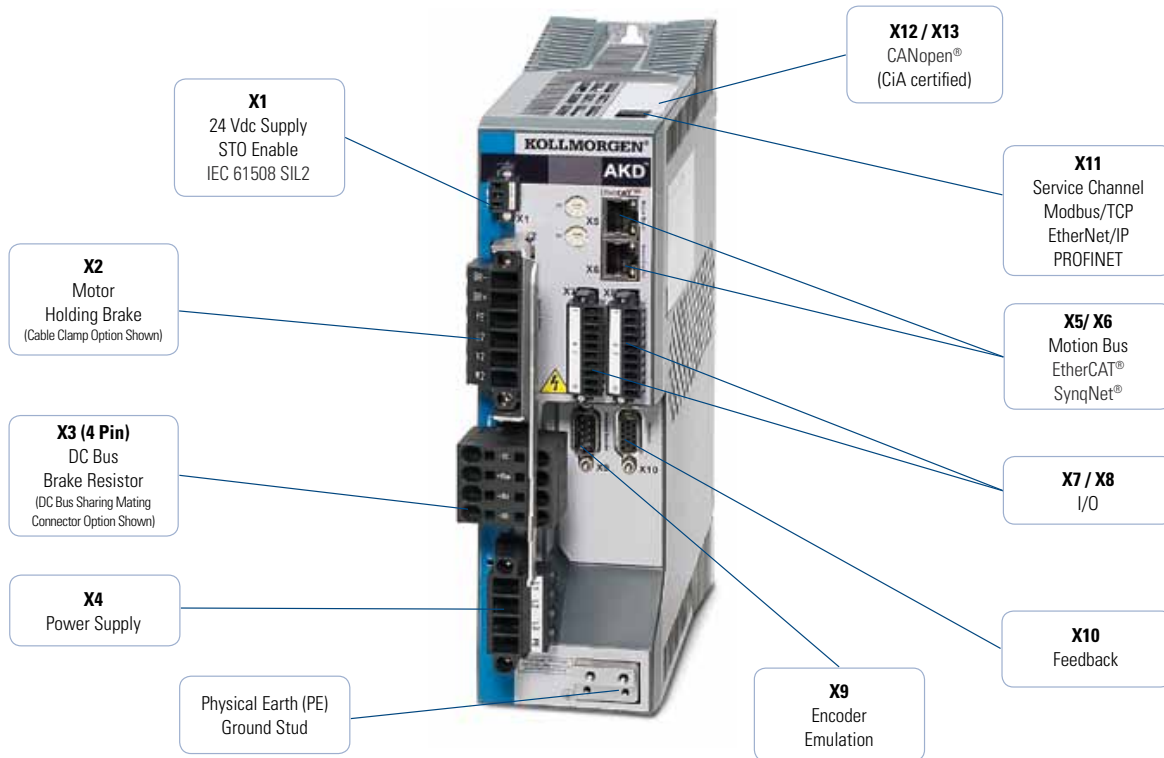

# Accessories



## CANopen Accessories

We offer cables, terminators and adaptors for simple integration with CANopen machine networks.



## Brake Resistors

We offer a full line of brake resistors up to 6000 watts. Brake resistors are impedance matched with AKD and are available in many sizes and form factors.



## Shielding Solutions

AKD servo drive can be equipped with shielding plates.



LEFT: Line filter  
RIGHT: Motor choke

## Chokes and Filters

Line filters are offered to improve reliability and to protect the life of the machine in less stable environments. Motor chokes reduce radiated emissions and are recommended for applications with cable lengths >25 meters.



## Motion Bus and Service Port Cables

We offer industrial shielded PUR cables with RJ45 connections for demanding industrial environments. These cables outperform office cables in EMC resilience, durability, and life.

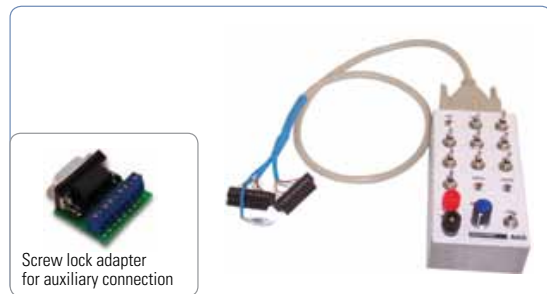

Screw lock adapter  
for auxiliary connection

## I/O Control Box and Breakout Adapter

Our I/O Control Box is pre-populated with I/O switches and a power connection for quicker prototyping.

# Servo System Cables

Value Line power and feedback cables are suitable for most standard applications. High-performance Flex Line power and feedback cables are available for trailing and flexing applications or where longer lengths are required.



## Mating Connectors

AKD servo drives include screw type mating connectors. Alternative connectors for DC Bus and mains sharing are also available. D-sub and RJ-type connectors are not included.

## Specification Comparison

	Value Line	Flex Line
Lengths offered	1, 3, 6, 9, 12 m	1-50 m, 1/2 m increments
Max ampacity (continuous)	12 A	24 A
Static flex radius	10 x Cable outside dimension (OD)	10 x Cable outside dimension (OD)
Dynamic flex (1,000,000 cycles)	Not rated	15 x Cable outside dimension (OD)
Motor connectors available	Euro style	Euro style
Maximum motor connector IP rating	IP67	IP65
Cable agency approvals	RoHS, UL, CE	UL, CSA, CE, NEC, NFPA
Feedback supported	SFD, EnDat2.2, 01, BiSS, resolver, HIPERFACE®	SFD, Sine Encoder, EnDat2.2, 01, BiSS, resolver, HIPERFACE®, comcoder
Holding brake	Available	Available

## Power Cables

AKD Servo Drive	Value Line	OD (mm)	Value Line with Brake	OD (mm)	Flex Line	OD (mm)	Flex Line with Brake	OD (mm)
3/6 Amp	VP-507BEAN-XX	9.4	VP-508CFAN-XX	10.9	CP-507CCAN-XX-X	12.7	CP-507CDAN-XX-X	14.5
12 Amp	VP-508CEAN-XX	10.3	VP-508CFAN-XX	10.9	CP-507CCAN-XX-X	12.7	CP-507CDAN-XX-X	14.5
20 Amp	VP-508DEAN-XX	11.7	VP-508DFAN-XX	12.9	CP-508DCAN-XX-X	14.5	CP-508DDAN-XX-X	16.6
24 Amp	Not available	Not available	Not available	Not available	CP-508EDBN-XX-X	18.3	CP-508EDBN-XX-X	18.3

## Feedback Cables

Feedback Type	Value Line	OD (mm)	Flex Line	OD (mm)
SFD	VF-DA0474N-XX	6.7	CF-DA0374N-XX-X	7.5
EnDat 2.1 / BiSS, HIPERFACE®	VF-SB4474N-XX	9.7	CF-SB7374N-XX-X	11.2
Resolver	VF-RA2474N-XX	9.7	CF-RA2574N-XX-X	9.5
Incremental / comcoder	Not available	Not available	CF-CB7374N-XX-X	11.2

Note: Refer to page 66 for matching cables by motor type and drive.

Sold & Serviced By:

 **ELECTROMATE**

Toll Free Phone (877) SERV098

Toll Free Fax (877) SERV099

[www.electromate.com](http://www.electromate.com)

[sales@electromate.com](mailto:sales@electromate.com)

# AKD Servo Systems

**When you need precise position control, choose from Kollmorgen's broad portfolio of AKD servo system components.** Our unparalleled product line breadth provides great flexibility for any application. Whether it's any combination of motors and drives, cables, controller, electric cylinders or gearheads, all components are plug-and-play for easy, seamless integration. These best-in-class servo systems can be matched with single-axis or multi-axis motion controllers for a system solution that's precise, reliable and durable.

Sold & Serviced By:

 **ELECTROMATE**

Toll Free Phone (877) SERV098

Toll Free Fax (877) SERV099

[www.electromate.com](http://www.electromate.com)

[sales@electromate.com](mailto:sales@electromate.com)

## The Benefits of AKD Servo Systems

<ul style="list-style-type: none"> <li>Optimized AKM and Direct Drive Motor Windings to AKD Servo Drive</li> </ul>	<ul style="list-style-type: none"> <li>Same size AKM servomotor delivers up to 47% more shaft power than before</li> <li>Reduction in drive size and motor size</li> <li>Reduction in system cost</li> </ul>
<ul style="list-style-type: none"> <li>Plug-and-Play Motor-Recognition Drive Commissioning for AKM, Cartridge DDR, and DDR Motor Families</li> <li>Industry-Leading and Patent Pending Auto-Tuning Algorithms</li> </ul>	<ul style="list-style-type: none"> <li>Reduction in set-up time for each servo system</li> <li>Immediate and adaptive response to dynamic loads optimizes performance in seconds</li> <li>Precise control of all motor types</li> <li>Compensation for stiff and compliant transmissions and couplings</li> </ul>
<ul style="list-style-type: none"> <li>New Lower Cost Multi-Turn Feedback Option</li> </ul>	<ul style="list-style-type: none"> <li>Improve machine precision with high resolution and improved accuracy</li> <li>Reduce cycle time and sensor-and-wiring costs by eliminating traditional homing methods</li> </ul>
<ul style="list-style-type: none"> <li>Industry-Leading Motor Power Density</li> </ul>	<ul style="list-style-type: none"> <li>Don't let motor size dictate the size of your machine</li> <li>Fit more motor into a smaller space than you thought possible</li> </ul>
<ul style="list-style-type: none"> <li>AKM Servomotor Offers 28 Frame-Stack Combinations and Nearly 120 Standard Windings in a Single Motor Line</li> <li>Cartridge DDR Motor Offers 17 Frame-Stack Combinations and 31 Windings</li> <li>Cartridge DDR Motor Offers 12 Frame-Stack Combinations and 12 Windings</li> </ul>	<ul style="list-style-type: none"> <li>Over 50,000 standard motor variations including a wide range of mounting, connectivity, feedback and other options</li> <li>Flexibility provides choices to help you find an exact-fit solution</li> <li>Simplifies or eliminates mechanical modifications and engineering adaptation</li> </ul>
<ul style="list-style-type: none"> <li>New IP67 Protection Class Option for AKM</li> </ul>	<ul style="list-style-type: none"> <li>Apply AKM servomotor into hostile industrial applications with confidence and long-term reliability</li> </ul>

Sold & Serviced By:

 **ELECTROMATE**

Toll Free Phone (877) SERV098

Toll Free Fax (877) SERV099

[www.electromate.com](http://www.electromate.com)

[sales@electromate.com](mailto:sales@electromate.com)

# AKM Servomotor

The AKM brushless servomotor stands alone in the marketplace in terms of flexibility and performance advantages. Kollmorgen's culture of continuous improvement has paid dividends again. The AKM servomotor's innovative design has been polished and optimized. With the new AKD servo drive amplifier, the AKM servomotor sets a new standard of refined servo performance, designed to deliver precise motion and more power for your money. Nowhere else will you find a more versatile and complete servo family to meet your needs and exceed your expectations.



## AKM Features

- 0.16 to 180 Nm continuous stall torque (1.4 to 1590 lb-in)
- 8 frame sizes (40 to 260 mm)
- 28 frame-stack length combinations
- 117 'standard' windings tailored for 75 Vdc and 120/240/400/480 Vac operation
- Flexible flange mount and shaft options
- Industry leading low-cogging contributing to extreme smoothness
- Numerous feedback options for high-performance and precision or rugged environment
- Unmatched customization – special windings, special shafts, and much more

## AKD Servo Drive with AKM Servomotor Plug-and-Play Feedback

These feedback devices include electronic motor nameplates allowing plug-and-play commissioning, eliminating the need for drive parameter set-up and servo loop tuning in most applications.

## Performance Data

AKM Servomotor	Single-turn Absolute			Multi-turn Absolute		
	Accuracy (arc-min)	Resolution (bits)	Motor Key	Accuracy (arc-min)	Resolution (bits)	Motor Key
AKM1	16	24	C	–	–	–
AKM2-3	9	24	C	8	20	LB
AKM4-8	9	24	C	4.66	21	LB
AKM2-4	1.0	27	DA	1.0	27	DB
AKM5-8	0.333	27	DA	0.333	27	DB

## AKM (Exploded) 3D Model Shows Key Design Features

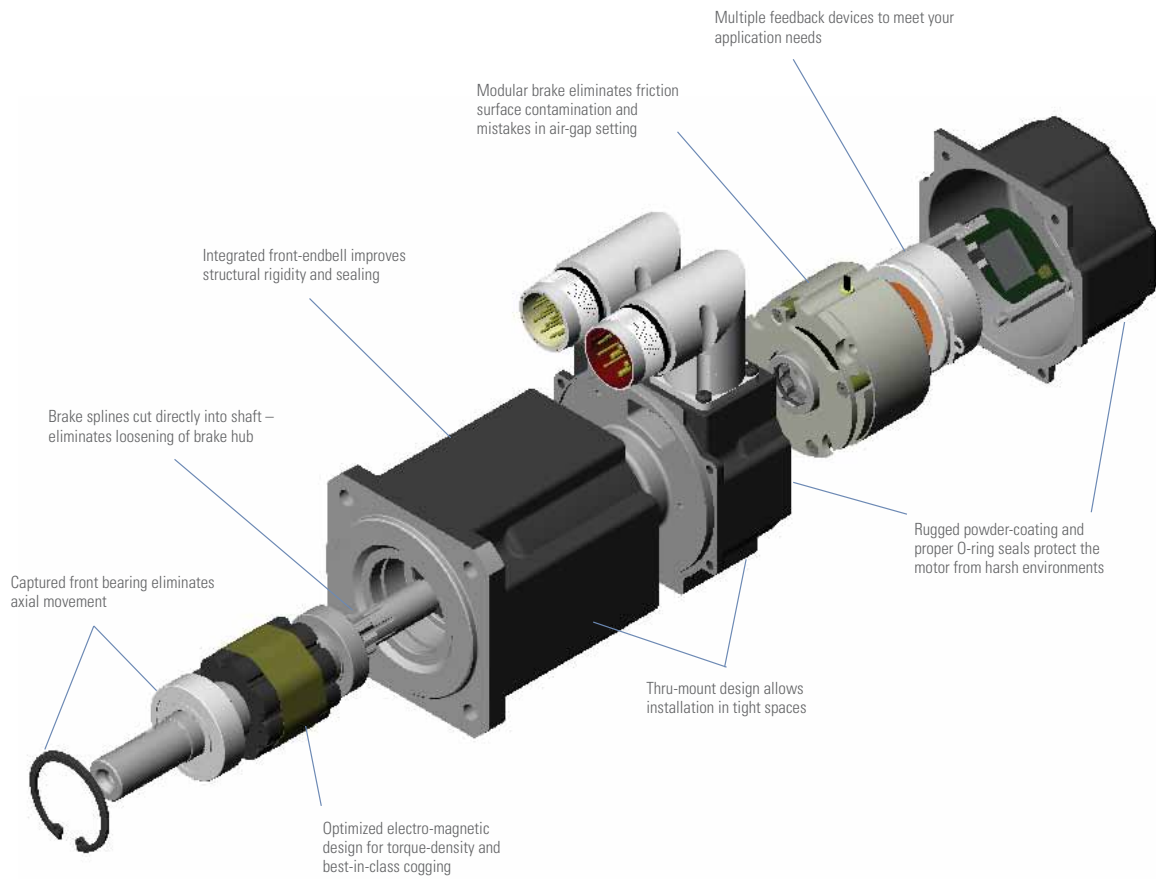

Sold & Serviced By:

 **ELECTROMATE**

Toll Free Phone (877) SERV098

Toll Free Fax (877) SERV099

[www.electromate.com](http://www.electromate.com)

[sales@electromate.com](mailto:sales@electromate.com)

# AKM Servomotor

AKD SERVO SYSTEMS

AKM SERVO MOTOR

## Performance Data

AKM Servomotor	AKD Servo Drive	Frame Size NEMA/ mm	Cont.Torque at stall Tcs Nm (lb-in)	Peak Torque at stall Tps Nm (lb-in)	Rated Speed Nrt'd RPM	Max System Speed RPM	Power Prtd Watts	Inertia (Jm) Kg-cm <sup>2</sup> (lb-in-s <sup>2</sup> x10 <sup>-2</sup> )	
120 Vac	AKM11B	AKD-X00306	17/ 40	0.18 (1.59)	0.61 (5.4)	4000	8000	80	0.017 (0.0015)
	AKM11C	AKD-X00306	17/ 40	0.19 (1.68)	0.62 (5.5)	6000	8000	110	0.017 (0.0015)
	AKM12C	AKD-X00306	17/ 40	0.31 (2.74)	1.08 (9.56)	4000	8000	130	0.031 (0.00274)
	AKM12E	AKD-X00306	17/ 40	0.31 (2.74)	0.91 (8.05)	8000	8000	230	0.031 (0.00274)
	AKM13C	AKD-X00306	17/ 40	0.41 (3.63)	1.46 (12.9)	3000	6150	130	0.045 (0.0040)
	AKM13D	AKD-X00306	17/ 40	0.40 (3.54)	1.36 (12.0)	7000	8000	270	0.045 (0.0040)
	AKM21C	AKD-X00306	23/ 60	0.48 (4.25)	1.48 (13.1)	2500	5620	120	0.107 (0.0095)
	AKM21E	AKD-X00306	23/ 60	0.47 (4.16)	1.21 (10.7)	7000	8000	300	0.107 (0.0095)
	AKM22C	AKD-X00306	23/ 60	0.84 (7.43)	2.39 (21.2)	1000	2820	90	0.161 (0.0142)
	AKM22E	AKD-X00306	23/ 60	0.87 (7.70)	2.42 (21.4)	3500	5410	290	0.161 (0.0142)
	AKM23D	AKD-X00306	23/ 60	1.15 (10.2)	3.89 (34.4)	1500	3270	180	0.216 (0.0191)
	AKM23F	AKD-X00606	23/ 60	1.18 (10.4)	3.88 (34.3)	4500	6290	500	0.216 (0.0191)
	AKM24D	AKD-X00306	23/ 60	1.40 (12.4)	4.84 (42.8)	1500	2700	210	0.270 (0.0239)
	AKM24F	AKD-X00606	23/ 60	1.41 (12.5)	4.82 (42.7)	3000	4720	420	0.270 (0.0239)
	AKM31E	AKD-X00306	na/ 80	1.20 (10.6)	3.23 (28.6)	2500	4240	310	0.330 (0.0292)
	AKM32E	AKD-X00306	na/ 80	2.04 (18.1)	5.97 (52.8)	1000	2350	210	0.590 (0.0522)
	AKM32H	AKD-X00606	na/ 80	2.10 (18.6)	6.22 (55.1)	3000	4460	620	0.590 (0.0522)
	AKM33H	AKD-X00606	na/ 80	2.87 (25.4)	8.55 (75.7)	2500	3310	690	0.850 (0.0752)
	AKM41E	AKD-X00306	34/ 90	2.01 (17.8)	5.33 (47.2)	1200	2420	240	0.810 (0.0717)
	AKM41H	AKD-X00606	34/ 90	2.05 (18.1)	5.49 (48.6)	3000	4460	580	0.810 (0.0717)
	AKM43H	AKD-X00606	34/ 90	4.82 (42.7)	14.0 (124)	1200	1920	560	2.09 (0.185)
	AKM43L	AKD-X01206	34/ 90	4.73 (41.9)	11.7 (104)	3000	4020	1190	2.09 (0.185)
	AKM44H	AKD-X00606	34/ 90	5.89 (43.3)	17.0 (150)	1000	1620	570	2.73 (0.242)
	AKM51H	AKD-X00606	42/ 115	4.79 (42.4)	11.7 (104)	1200	2150	560	3.42 (0.303)
	AKM51L	AKD-X01206	42/ 115	4.89 (43.3)	10.6 (93.8)	3000	4150	1240	3.42 (0.303)
	AKM52L	AKD-X01206	42/ 115	8.67 (76.7)	19.6 (173)	1500	2290	1240	6.22 (0.551)
	AKM53L	AKD-X01206	42/ 115	11.6 (103)	26.5 (235)	1200	1740	1350	9.12 (0.807)
	AKM54L	AKD-X01206	42/ 115	13.5 (119)	31.3 (277)	1200	1510	1630	11.9 (1.06)
240 Vac	AKM11B	AKD-X00306	17/ 40	0.18 (1.59)	0.61 (5.4)	8000	8000	140	0.017 (0.0015)
	AKM12C	AKD-X00306	17/ 40	0.31 (2.74)	1.08 (9.56)	8000	8000	230	0.031 (0.00274)
	AKM13C	AKD-X00306	17/ 40	0.41 (3.63)	1.46 (12.9)	8000	8000	300	0.045 (0.0040)
	AKM21C	AKD-X00306	23/ 60	0.48 (4.25)	1.48 (13.1)	8000	8000	320	0.107 (0.0095)
	AKM22C	AKD-X00306	23/ 60	0.84 (7.43)	2.73 (24.2)	3500	5650	290	0.161 (0.0142)
	AKM22E	AKD-X00306	23/ 60	0.87 (7.70)	2.42 (21.4)	8000	8000	580	0.161 (0.0142)
	AKM23D	AKD-X00306	23/ 60	1.15 (10.2)	3.89 (34.4)	5000	6540	530	0.216 (0.0191)
	AKM23F	AKD-X00606	23/ 60	1.18 (10.4)	3.88 (34.3)	8000	8000	780	0.216 (0.0191)
	AKM24D	AKD-X00306	23/ 60	1.40 (12.4)	4.84 (42.8)	4000	5410	540	0.270 (0.0239)
	AKM24F	AKD-X00606	23/ 60	1.41 (12.5)	4.82 (42.7)	8000	8000	930	0.270 (0.0239)
	AKM31C	AKD-X00306	na/ 80	1.15 (10.2)	3.87 (34.3)	2500	4050	290	0.330 (0.0292)
	AKM31E	AKD-X00306	na/ 80	1.20 (10.6)	3.23 (28.6)	6000	8000	600	0.330 (0.0292)
	AKM32E	AKD-X00306	na/ 80	2.04 (18.1)	5.97 (52.8)	3000	4710	600	0.590 (0.0522)
	AKM32H	AKD-X00606	na/ 80	2.10 (18.6)	6.22 (55.1)	7000	8000	1060	0.590 (0.0522)
	AKM33E	AKD-X00306	na/ 80	2.80 (24.8)	8.95 (79.2)	2000	3130	550	0.850 (0.0752)
	AKM33H	AKD-X00606	na/ 80	2.87 (25.4)	8.55 (75.7)	5500	6640	1300	0.850 (0.0752)
	AKM41E	AKD-X00306	34/ 90	2.01 (17.8)	5.33 (47.2)	3000	4850	570	0.810 (0.0717)
	AKM41H	AKD-X00606	34/ 90	2.05 (18.1)	5.49 (48.6)	6000	6000	1010	0.810 (0.0717)
	AKM42E	AKD-X00306	34/ 90	3.42 (30.3)	9.74 (86.2)	1800	2740	590	1.45 (0.128)
	AKM42G	AKD-X00606	34/ 90	3.51 (31.1)	11.0 (97.4)	3500	4660	1060	1.45 (0.128)
	AKM43H	AKD-X00606	34/ 90	4.82 (42.7)	14.0 (124)	3000	3850	1210	2.09 (0.185)
	AKM43L	AKD-X01206	34/ 90	4.73 (41.9)	11.7 (104)	6000	6000	1590	2.09 (0.185)
	AKM44E	AKD-X00306	34/ 90	5.79 (51.2)	16.5 (146)	1200	1680	660	2.73 (0.242)
	AKM44H	AKD-X00606	34/ 90	5.89 (43.3)	17.0 (150)	2500	3250	1220	2.73 (0.242)

Note 1: Refer to page 66 for matching cables.

Note 2: For complete AKD and AKM model nomenclature, refer to pages 67 and 68 respectively.

Note 3: Max mechanical speeds: 8000 RPM for AKM1, 2, 3 and 6000 RPM for AKM4, 5, 6, 7.

Sold & Serviced By:

 **ELECTROMATE**

Toll Free Phone (877) SERV098

Toll Free Fax (877) SERV099

[www.electromate.com](http://www.electromate.com)

[sales@electromate.com](mailto:sales@electromate.com)



## Performance Data

AKM Servomotor	AKD Servo Drive	Frame Size NEMA/ mm	Cont.Torque at stall Tcs Nm (lb-in)	Peak Torque at stall Tps Nm (lb-in)	Rated Speed Nrtd RPM	Max System Speed RPM	Power Prtd Watts	Inertia (Jm) Kg-cm <sup>2</sup> (lb-in-s <sup>2</sup> x10 <sup>-2</sup> )	
240 Vac	AKM51H	AKD-X00606	42/ 115	4.79 (42.4)	11.7 (104)	3000	4030	1220	3.42 (0.303)
	AKM51L	AKD-X01206	42/ 115	4.89 (43.3)	10.6 (93.8)	6000	6000	1260	3.42 (.0303)
	AKM52H	AKD-X00606	42/ 115	8.48 (75.1)	21.6 (191)	1800	2390	1420	6.22 (0.551)
	AKM52L	AKD-X01206	42/ 115	8.67 (76.7)	19.6 (173)	3500	4580	2350	6.22 (0.551)
	AKM53H	AKD-X00606	42/ 115	10.5 (92.9)	27.8 (246)	1500	1970	1650	9.12 (0.807)
	AKM53L	AKD-X01206	42/ 115	11.6 (103)	26.5 (235)	2500	3450	2510	9.12 (0.807)
	AKM54H	AKD-X00606	42/ 115	14.2 (126)	37.5 (332)	1000	1340	1400	11.9 (1.06)
	AKM54L	AKD-X01206	42/ 115	13.5 (119)	31.3 (277)	2500	3030	3010	11.9 (1.06)
	AKM62H	AKD-X00606	na/ 142	11.9 (105)	29.6 (262)	1000	1560	1170	16.9 (1.50)
	AKM62L	AKD-X01206	na/ 142	12.2 (108)	26.3 (233)	2500	3380	2620	16.9 (1.50)
	AKM63L	AKD-X01206	na/ 142	16.8 (149)	39.3 (348)	1500	2260	2330	24.2 (2.14)
	AKM63N	AKD-X02406	na/ 142	17.0 (150)	40.3 (357)	3000	3450	4080	24.2 (2.14)
	AKM64L	AKD-X01206	na/ 142	19.7 (174)	44.4 (393)	1500	2070	2890	31.6 (2.80)
	AKM64Q	AKD-X02406	na/ 142	19.5 (173)	43.1 (381)	3000	3440	4810	31.6 (2.80)
	AKM65L	AKD-X01206	na/ 142	24.6 (218)	55.4 (490)	1300	1660	3040	40.0 (3.54)
	AKM65P	AKD-X02406	na/ 142	24.5 (217)	53.9 (477)	2400	2750	4790	40.0 (3.54)
	AKM72P	AKD-X02406	na/ 180	29.5 (261)	65.8 (606)	1800	2170	4500	64.5 (5.71)
	AKM72Q	AKD-X02406	na/ 180	24.5 (217)	56.0 (496)	2000	2730	4860	64.5 (5.71)
AKM73P	AKD-X02406	na/ 180	41.4 (366)	95.3 (828)	1300	1610	4700	92.1 (8.15)	
AKM73Q	AKD-X02406	na/ 180	33.0 (292)	76.1 (674)	1500	2020	5250	92.1 (8.15)	
AKM74Q	AKD-X02406	na/ 180	46.8 (414)	90.7 (803)	1200	1710	5380	120 (10.6)	
400 Vac	AKM22C	AKD-X00307	23/ 60	0.84 (7.43)	2.73 (24.2)	8000	8000	570	0.161 (0.0142)
	AKM23D	AKD-X00307	23/ 60	1.15 (10.2)	3.89 (34.4)	8000	8000	760	0.216 (0.0191)
	AKM24D	AKD-X00307	23/ 60	1.40 (12.4)	4.84 (42.8)	8000	8000	920	0.270 (0.0239)
	AKM31C	AKD-X00307	na/ 80	1.15 (10.2)	3.87 (34.3)	5000	7100	520	0.330 (0.0292)
	AKM32E	AKD-X00307	na/ 80	2.04 (18.1)	5.97 (52.8)	6500	8000	1020	0.590 (0.0522)
	AKM33E	AKD-X00307	na/ 80	2.80 (24.8)	8.95 (79.2)	4500	5490	1100	0.850 (0.0752)
	AKM41E	AKD-X00307	34/ 90	2.01 (17.8)	5.33 (47.2)	6000	6000	990	0.810 (0.0717)
	AKM42E	AKD-X00307	34/ 90	3.42 (30.3)	9.74 (86.2)	3500	4790	1030	1.45 (0.128)
	AKM42G	AKD-X00607	34/ 90	3.51 (31.1)	11.0 (97.4)	6000	6000	1470	1.45 (0.128)
	AKM43H	AKD-X00607	34/ 90	4.82 (42.7)	14 (124)	5500	6000	1620	2.09 (0.185)
	AKM44E	AKD-X00307	34/ 90	5.79 (51.2)	16.5 (146)	2000	2940	1010	2.73 (0.242)
	AKM44H	AKD-X00607	34/ 90	5.89 (43.3)	17.0 (150)	4500	5710	1640	2.73 (0.242)
	AKM51H	AKD-X00607	42/ 115	4.79 (42.4)	11.7 (104)	6000	6000	1230	3.42 (0.303)
	AKM52H	AKD-X00607	42/ 115	8.48 (75.1)	21.6 (191)	3500	4180	2290	6.22 (0.551)
	AKM52L	AKD-X01207	42/ 115	8.67 (76.7)	19.6 (173)	6000	6000	2050	6.22 (0.551)
	AKM53H	AKD-X00607	42/ 115	10.5 (92.9)	27.8 (246)	3000	3450	2770	9.12 (0.807)
	AKM53L	AKD-X01207	42/ 115	11.6 (103)	26.5 (235)	5000	6000	3140	9.12 (0.807)
	AKM54H	AKD-X00607	42/ 115	14.2 (126)	37.5 (332)	1800	2340	2350	11.9 (1.06)
	AKM54L	AKD-X01207	42/ 115	13.5 (119)	31.3 (277)	4500	5310	3830	11.9 (1.06)
	AKM62H	AKD-X00607	na/ 142	11.9 (105)	29.6 (262)	2000	2730	2140	16.9 (1.50)
	AKM62L	AKD-X01207	na/ 142	12.2 (108)	26.3 (233)	5000	5920	3880	16.9 (1.50)
	AKM63L	AKD-X01207	na/ 142	16.8 (149)	39.3 (348)	3000	3950	4040	24.2 (2.14)
	AKM63N	AKD-X02407	na/ 142	17.0 (150)	40.3 (357)	5000	6000	4900	24.2 (2.14)
	AKM64L	AKD-X01207	na/ 142	19.7 (174)	44.4 (393)	3000	3640	4900	31.6 (2.80)
	AKM64Q	AKD-X02407	na/ 142	19.5 (173)	43.1 (381)	5000	6000	5600	31.6 (2.80)
	AKM65L	AKD-X01207	na/ 142	24.6 (218)	55.4 (490)	2500	2910	5030	40.0 (3.54)
	AKM65P	AKD-X02407	na/ 142	24.5 (217)	53.9 (477)	4000	4820	6240	40.0 (3.54)
	AKM72L	AKD-X01207	na/ 180	30.0 (266)	70.5 (624)	1500	2300	3970	64.5 (5.71)
	AKM72P	AKD-X02407	na/ 180	29.5 (261)	68.5 (606)	3000	3800	6280	64.5 (5.71)
	AKM72Q	AKD-X02407	na/ 180	24.5 (217)	56.0 (496)	4000	4780	6830	64.5 (5.71)
	AKM73L	AKD-X01207	na/ 180	41.7 (369)	95.4 (844)	1400	1720	5060	92.1 (8.15)
	AKM73P	AKD-X02407	na/ 180	41.4 (366)	93.5 (828)	2400	2820	7130	92.1 (8.15)
	AKM73Q	AKD-X02407	na/ 180	33.0 (292)	76.1 (674)	3000	3550	7920	92.1 (8.15)
	AKM74L	AKD-X01207	na/ 180	49.7 (440)	114 (1010)	1200	1450	5470	120 (10.6)
AKM74P	AKD-X02407	na/ 180	52.3 (463)	125 (1110)	1800	2110	7050	120 (10.6)	
AKM74Q	AKD-X02407	na/ 180	46.8 (414)	90.7 (803)	2500	3000	8250	120 (10.6)	

Note 1: Refer to page 66 for matching cables.

Note 2: For complete AKD and AKM model nomenclature, refer to pages 67 and 68 respectively.

Note 3: Max mechanical speeds: 8000 RPM for AKM1, 2, 3 and 6000 RPM for AKM4, 5, 6, 7

Sold &amp; Serviced By:



Toll Free Phone (877) SERV098

Toll Free Fax (877) SERV099

www.electromate.com

sales@electromate.com

# AKM Servomotor

AKD SERVO SYSTEMS

AKM SERVO MOTOR

## Performance Data

AKM Servomotor	AKD Servo Drive	Frame Size NEMA/ mm	Cont.Torque at stall Tcs Nm (lb-in)	Peak Torque at stall Tps Nm (lb-in)	Rated Speed Nrt'd RPM	Max System Speed RPM	Power Prtd Watts	Inertia (Jm) Kg-cm <sup>2</sup> (lb-in-s <sup>2</sup> x10 <sup>-2</sup> )
AKM22C	AKD-X00307	23/ 60	0.84 (7.43)	2.34 (20.7)	8000	8000	570	0.161 (0.0142)
AKM23D	AKD-X00307	23/ 60	1.15 (10.2)	3.89 (34.4)	8000	8000	760	0.216 (0.0191)
AKM24D	AKD-X00307	23/ 60	1.40 (12.4)	4.84 (42.8)	8000	8000	920	0.270 (0.0239)
AKM31C	AKD-X00307	na/ 80	1.15 (10.2)	3.35 (29.7)	6000	8000	570	0.330 (0.0292)
AKM32E	AKD-X00307	na/ 80	2.04 (18.1)	5.97 (52.8)	8000	8000	1020	0.590 (0.0522)
AKM33E	AKD-X00307	na/ 80	2.80 (24.8)	8.95 (79.2)	5000	6280	1190	0.850 (0.0752)
AKM41E	AKD-X00307	34/ 90	2.01 (17.8)	5.33 (47.2)	6000	6000	990	0.810 (0.0717)
AKM42E	AKD-X00307	34/ 90	3.42 (30.3)	9.74 (86.2)	4000	5470	1140	1.45 (0.128)
AKM42G	AKD-X00607	34/ 90	3.51 (31.1)	11.0 (97.4)	6000	6000	1470	1.45 (0.128)
AKM43H	AKD-X00607	34/ 90	4.82 (42.7)	14.0 (124)	6000	6000	1620	2.09 (0.185)
AKM44E	AKD-X00307	34/ 90	5.79 (51.2)	16.5 (146)	2500	3370	1200	2.73 (0.242)
AKM44H	AKD-X00607	34/ 90	5.89 (43.3)	17.0 (150)	5500	6000	1690	2.73 (0.242)
AKM51H	AKD-X00607	42/ 115	4.79 (42.4)	11.7 (104)	6000	6000	1230	3.42 (0.303)
AKM52H	AKD-X00607	42/ 115	8.48 (75.1)	21.6 (191)	4000	4780	2420	6.22 (0.551)
AKM52L	AKD-X01207	42/ 115	8.67 (76.7)	19.6 (173)	6000	6000	2050	6.22 (0.551)
AKM53H	AKD-X00607	42/ 115	10.5 (92.9)	27.8 (246)	3000	3940	2770	9.12 (0.807)
AKM53L	AKD-X01207	42/ 115	11.6 (103)	26.5 (235)	6000	6000	2540	9.12 (0.807)
AKM54H	AKD-X00607	42/ 115	14.2 (126)	37.5 (332)	2000	2680	2560	11.9 (1.06)
AKM54L	AKD-X01207	42/ 115	13.5 (119)	31.3 (277)	5000	6000	3690	11.9 (1.06)
AKM62H	AKD-X00607	na/ 142	11.9 (105)	29.6 (262)	2400	3120	2480	16.9 (1.50)
AKM62L	AKD-X01207	na/ 142	12.2 (108)	26.3 (233)	6000	6000	3610	16.9 (1.50)
AKM63L	AKD-X01207	na/ 142	16.8 (149)	39.3 (348)	3500	5410	4400	24.2 (2.14)
AKM63N	AKD-X02407	na/ 142	17.0 (150)	40.3 (357)	6000	6000	4400	24.2 (2.14)
AKM64L	AKD-X01207	na/ 142	19.7 (174)	44.4 (393)	3500	4160	5280	31.6 (2.80)
AKM64Q	AKD-X02407	na/ 142	19.5 (173)	43.1 (381)	6000	6000	4620	31.6 (2.80)
AKM65L	AKD-X01207	na/ 142	24.6 (218)	55.4 (490)	2800	3320	5450	40.0 (3.54)
AKM65P	AKD-X02407	na/ 142	24.5 (217)	53.9 (477)	4500	5500	6360	40.0 (3.54)
AKM72L	AKD-X01207	na/ 180	30.0 (266)	70.5 (624)	1800	2630	4580	64.5 (5.71)
AKM72P	AKD-X02407	na/ 180	29.5 (261)	68.5 (606)	3000	4340	6680	64.5 (5.71)
AKM72Q	AKD-X02407	na/ 180	24.5 (217)	56.0 (496)	4500	5460	6640	64.5 (5.71)
AKM73L	AKD-X01207	na/ 180	41.7 (369)	95.4 (844)	1500	1970	5620	92.1 (8.15)
AKM73P	AKD-X02407	na/ 180	41.4 (366)	93.5 (828)	2400	3220	7130	92.1 (8.15)
AKM73Q	AKD-X02407	na/ 180	33.0 (292)	76.1 (674)	3500	4050	8060	92.1 (8.15)
AKM74L	AKD-X01207	na/ 180	49.7 (440)	114 (1010)	1400	1660	6080	120 (10.6)
AKM74P	AKD-X02407	na/ 180	52.3 (463)	125 (1110)	1800	2420	7050	120 (10.6)
AKM74Q	AKD-X02407	na/ 180	46.8 (414)	90.7 (803)	3000	3430	8580	120 (10.6)

Note 1: Refer to page 66 for matching cables.

Note 2: For complete AKD and AKM model nomenclature, refer to pages 67 and 68 respectively.

Note 3: Max mechanical speeds: 8000 RPM for AKM1, 2, 3 and 6000 RPM for AKM4, 5, 6, 7.

Sold & Serviced By:

 **ELECTROMATE**

Toll Free Phone (877) SERV098

Toll Free Fax (877) SERV099

[www.electromate.com](http://www.electromate.com)

[sales@electromate.com](mailto:sales@electromate.com)

### Model with Power Connector

Outline indicative of AKM11 - AKM74

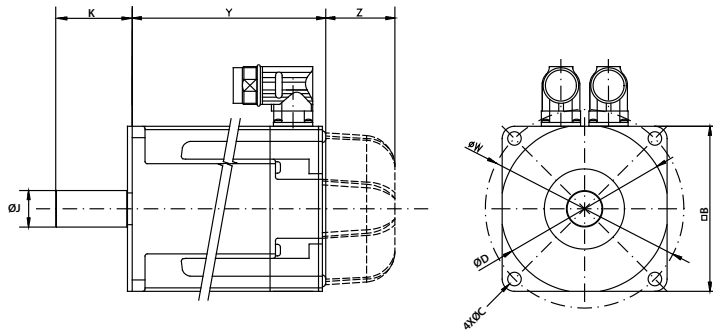

### Model with Terminal Box

Outline indicative of AKM82 - AKM84

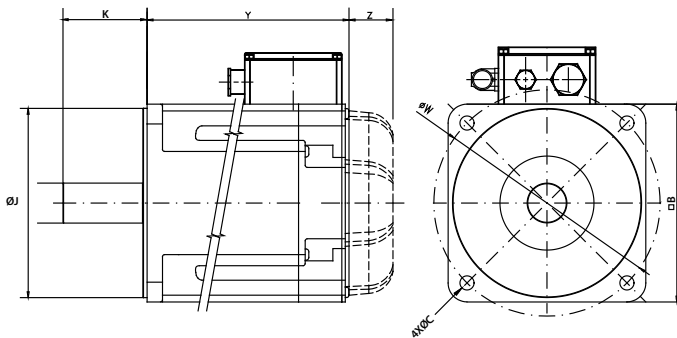

### Dimensions (mm)

Model	Shaft **	Shaft Length	Mount Hole **	Length 1 stack (AKMx1)	Length 2 stack (AKMx2)	Length 3 stack (AKMx3)	Length 4 stack (AKMx4)	Length 5 stack (AKMx5)	Brake Adder	Sine Enc. Adder *
	"J"	"K"	"C"	"Y"	"Y"	"Y"	"Y"	"Y"		
AKM1	8	25	4.3	79	98	117	n/a	n/a	n/a	n/a
AKM2	9	20	4.8	95.4	114.4	133.4	152.4	n/a	34.1	0
AKM3	14	30	5.8	109.8	140.8	171.8	n/a	n/a	30.5	0
AKM4	19	40	7	118.8	147.8	176.8	205.8	n/a	33.5	0
AKM5	24	50	9	127.5	158.5	189.5	220.5	n/a	45	18.5
AKM6	32	58	11	n/a	153.7	178.7	203.7	228.7	47	18.5
AKM7	38	80	13.5	n/a	192.5	226.5	260.5	n/a	42	9.5
AKM8	48	110	18.5	n/a	263.4	343.9	424.4	n/a	66	0

Model	Frame Square "B"	Mount Pilot **	Mount B.C. **	Model	Frame Square "B"	Mount Pilot **	Mount B.C. **
AKM1	40	30	36	AKM5	108	110	130
AKM2	58	40	63	AKM6	138	130	165
AKM3	70	60	75	AKM7	188	180	215
AKM4	84	80	100	AKM8	260	250	300

\* AKM5x w/ Sine Enc. and brake, plus adders, -2.0 mm.  
AKM6x w/ Sine Enc. and brake, plus adders, +0.5 mm.  
AKM7x w/ Sine Enc. and brake, plus adders, +9.3 mm.

\*\* Assumes the "A" international mount, other mounts available see AKM selection guide online.

Sold & Serviced By:

ELECTROMATE

Toll Free Phone (877) SERV098

Toll Free Fax (877) SERV099

www.electromate.com

sales@electromate.com

# Direct Drive Technology (DDT)

Conventional servo systems commonly have a mechanical transmission which can consist of gears, gearheads, belts/pulleys or cams connected between the motor and the load.

With direct drive technology, the mechanical transmission is eliminated and the motor is coupled directly to the load.

## Why Use Direct Drive Technology?

### Increased Accuracy and Repeatability

A "precision" planetary gearhead could have a backlash of 1 arc-minute. This can result in the load moving by 1 arc-minute with an absolutely stationary drive motor. Kollmorgen's standard direct drive rotary (DDR) servomotors have repeatability better than 1 arc-second. Therefore, a direct drive motor can hold a position 60 times better than a conventional motor/gearhead.

The increased accuracy of direct drive technology results in a higher quality product out of the machine:

- Print registration is more accurate
- Cut or feed lengths can be held more precisely
- Coordination with other machine axes is more accurate
- Indexing location is more exact
- Tuning issues due to backlash are eliminated

### Higher Bandwidth

Mechanical transmission components impose a limit on how fast a machine can start and stop and also extend the required settling time. These factors limit the possible throughput of a machine.

Direct drive technology removes these limitations and allows for much faster start/stop cycles and also provides greatly reduced settling time. This will allow a greater throughput from the machine. Users of direct drive systems have reported up to a 2X increase in throughput.

### Improved Reliability and Zero Maintenance

Gears, belts, and other mechanical transmission parts break. By eliminating these parts and using DDR motors, the reliability of the machine is improved. Gearheads require periodic lubrication and/or replacement in aggressive start/stop applications. Belts require periodic tightening. There are no time-wear components in a direct drive motor and consequently they require zero maintenance.

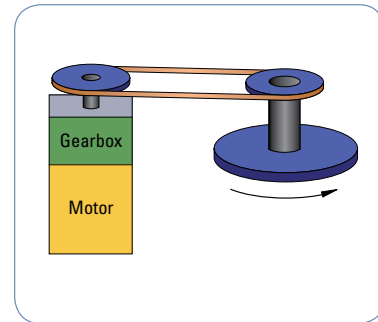

*Servomotor and gearhead*

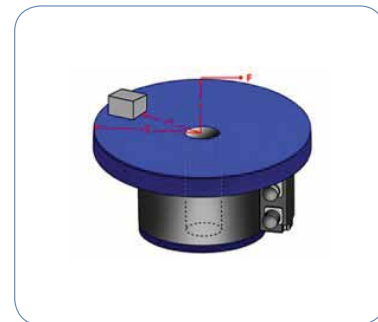

*Direct drive motor*

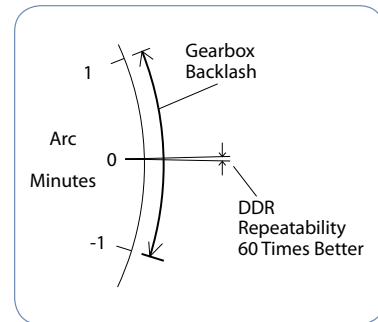

*Improved repeatability*

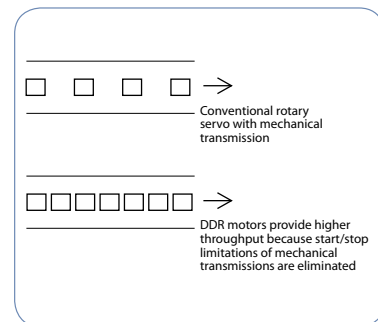

*Increased throughput*

## Fewer Parts

With direct drive motors, all you need is the motor and the mounting bolts. This often replaces many parts including brackets, guards, belts, pulleys, tensioners, couplings, and bolts, resulting in:

- Fewer parts on the BOM. Fewer parts to purchase, schedule, inventory and control, and fewer parts to assemble.
- Assembly time of the servo drops from several hours with the mechanical transmission to several minutes with the DDR.
- Reduced cost. Although a direct drive motor may carry a small price-premium compared to a motor/gearhead with the same torque, consider that there is an overall cost reduction when eliminating the parts and labor of all the extra components required in a servo system with mechanical transmission.

## No Inertia Matching

Servo systems with mechanical transmissions require inertia matching that limits the reflected load inertia at 5 to 10 times the motor inertia. If this limitation is not met, the system becomes difficult to control due to instability issues. Inertia matching limitations of mechanical transmission systems often force machine designers to use a larger motor than would otherwise be required just to satisfy the inertia matching requirement.

Such sizing conventions are not required with direct drive technology. Since the motor is directly connected to the load, the inertia of the motor and the load become a common inertia. Therefore, no inertia matching is required when using DDR. DDR applications have run with inertia ratios greater than 11,000:1.

## Reduced Audible Noise

Machines with DDR motors have audible noise levels as low as 20 dB less than the same machine with a mechanical transmission.

## Three DDR Product Categories to Choose From

Kollmorgen's 50 years of electromagnetic and electromechanical design experience combined with our quality and service, allowed us to refine and expand DDR technology into three product categories for easy installation, use, and short lead times: [Frameless DDR](#), [Housed DDR](#), and the [Cartridge DDR](#). This allows you to select the right DDR solution for your application.

### F Series Frameless DDR

Frameless motors include a rotor and stator as separate components which are integrated into, ride on the bearings of, and become a part of the driven load. Frameless motors offer the most compact and lightweight DDR solution available. The "F" series is Kollmorgen's latest frameless DDR product. It provides excellent torque/volume with the use of a proprietary neodymium-iron magnet rotor structure and skewed armature assembly. The F series is the first UL recognized parts set available on the market. This provides OEMs with the benefits of UL component ratings for easier agency approval on their machines.

### Housed DDR

The Housed DDR is a housed motor assembly featuring a factory aligned high-resolution feedback device and precision bearings, allowing it to function as the core of rotary indexing and rate table applications. The system can also be used as a flexible indexer, providing programmable, rapid indexing far exceeding the throughput and accuracy of conventional mechanical or variable reluctance technology indexers.

### Cartridge DDR

This motor is the first in the industry to combine the space-saving and performance advantages of frameless DDR technology with the ease of installation of a full-frame motor. Consisting of a rotor, stator, and factory-aligned high-resolution feedback device, the motor uses the machine's bearings to support the rotor. An innovative compression coupling engages the rotor to the load and the frame of the motor mounts to the machine with a bolt circle and pilot diameter just like a conventional servomotor, saving space and design time and simplifying the overall system.

## DDR Applications

Format	Where Used
Frameless DDR	Application where size and weight must be absolutely minimized
Housed DDR	Applications where the load rides on the motor's bearings such as indexing or rate tables
Cartridge DDR	Any application with existing bearings

Sold & Serviced By:

 **ELECTROMATE**

Toll Free Phone (877) SERV098

Toll Free Fax (877) SERV099

[www.electromate.com](http://www.electromate.com)

[sales@electromate.com](mailto:sales@electromate.com)

# Cartridge Direct Drive Rotary (DDR) Motor

AKD SERVO SYSTEMS

CARTRIDGE DIRECT DRIVE ROTARY MOTOR

The Cartridge Direct Drive Rotary (DDR) motor is the first in the industry to combine the space-saving and performance advantages of frameless DDR technology with the ease of installation of a full-frame motor. Cartridge DDR motors also feature an advanced electromagnetic design that provides up to 50% more torque density than comparably sized conventional servomotors.

Consisting of a rotor, stator and factory-aligned high-resolution feedback device, the Cartridge DDR motor uses the machine's bearings to support the rotor.

An innovative compression coupling secures the Cartridge DDR's rotor to the machine shaft, and the Cartridge DDR's housing is bolted to the machine frame with a bolt circle and pilot – just like a conventional servomotor – saving space and design time and simplifying the overall system.

Conventional servo systems typically include a number of mechanical transmission components that limit the performance and reliability, and drive up cost of operation. Cartridge DDR motors eliminate all mechanical transmission parts, resulting in the following features:

## Cartridge DDR Features

- Assembles as quickly as 5 minutes
- 5 frame sizes, multiple lengths
- Continuous torque range: 4.57 Nm (3.37 lb-ft) to 510 Nm (373 lb-ft), accommodates a wide range of high-power application requirements
- Optimized torque output with high-pole count efficient electromagnetic design
- Integrated high resolution sine encoder
- 134,217,728 counts/rev
- Speeds up to 2,500 RPM meets most medium speed and high-torque application requirements
- Direct load connection eliminates gearheads, belts and pulleys
- Low cogging for smooth low-speed rotation
- Zero backlash and compliance provides more responsive system performance



Sold & Serviced By:

 **ELECTROMATE**

Toll Free Phone (877) SERV098

Toll Free Fax (877) SERV099

[www.electromate.com](http://www.electromate.com)

[sales@electromate.com](mailto:sales@electromate.com)

## The Cartridge DDR Advantage – Press Feed Machine

Consider how Cartridge DDR technology improves a press feed machine:

### Reduced Assembly Time

The assembly time for the original mechanical transmission system was 4 hours. In contrast, the Cartridge DDR motor is installed in less than 5 minutes, resulting in a significant cost savings in labor.

### Reduced Parts Count

The original mechanical transmission system comprises 2 bracket pieces, 12 bolts, 2 pulleys, 2 set screws, 2 keys, a timing belt, a housing to protect operators from the timing belt, a tension system for the timing belt, and motor/gearhead. With the Cartridge DDR system, this is all replaced by the motor and 4 mounting bolts, resulting in fewer parts to maintain and cost savings.

### Improved Accuracy

The best planetary gearheads have a backlash between 1 and 2 arc-minutes. Over the life of the gearhead, the backlash will increase. The Cartridge DDR system has an absolute accuracy of 26 arc-seconds and a repeatability of 0.7 arc-seconds. The press feed machine with the Cartridge DDR has a feed accuracy of +/- 0.0005 inch where the press feed machine with the mechanical transmission has a feed accuracy of 0.002 inch. Therefore, there was an overall four times improvement in machine accuracy with the Cartridge DDR system.

### Increased Throughput

The cycle rate of the Cartridge DDR system is two times better than the mechanical transmission. This results in an increase in throughput of 100 percent.

## Improved Reliability and Simplified Maintenance

The Cartridge DDR system eliminates parts that wear, change over time, or fail. Gearheads are prone to wear, and backlash increases over time. Belts and pulleys stretch and require maintenance to maintain proper belt tension. By eliminating these components, the Cartridge DDR system delivers greater system reliability.

### Press Feed Example

Gearheads have a finite life span, especially in a demanding cyclic application such as a press feed. On this machine, the gearhead must be replaced every 10,000 hours and the belt must be tensioned every 2,000 hours. By contrast, the Cartridge DDR motor has no wear components and requires no maintenance thus simplifying the maintenance schedule for the machine, including operating costs.

### Reduced Audible Noise

The Cartridge DDR system has as much as a 20 dB reduction in noise compared to a mechanical transmission servo system. This can dramatically reduce the overall noise level of the machine. A quieter machine gives the perception of quality. This is rightfully so as the noise emitted by gears and belts is caused by the wearing of the parts.

### Total Reduced Cost

A Cartridge DDR motor typically costs 20 percent more than a comparable motor/gearhead combination. However, the elimination of parts and assembly time typically results in a lower total cost for the Cartridge DDR solution.



*Press feed machine built with a conventional servomotor, gearhead, belt and pulleys.*

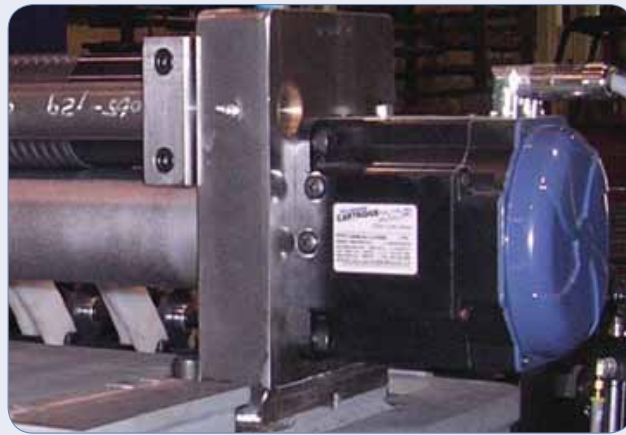

*Same machine with a Cartridge DDR motor installed. Here, the shaft of the driven roll is extended into the Cartridge DDR motor and the motor applies torque directly to the driven roll.*

Sold & Serviced By:

 **ELECTROMATE**

Toll Free Phone (877) SERV098

Toll Free Fax (877) SERV099

[www.electromate.com](http://www.electromate.com)

[sales@electromate.com](mailto:sales@electromate.com)

# Cartridge Direct Drive Rotary Motor (DDR)

AKD SERVO SYSTEMS

CARTRIDGE DIRECT DRIVE ROTARY MOTOR

## 240 Vac Performance Data

Cartridge DDR Motor	AKD Servo Drive	Frame Size	Continuous Torque	Peak Torque	Maximum Speed	Weight	Inertia (Jm)
		mm (in)	Nm (lb-in)	Nm (lb-in)	RPM	kg (lb)	kg-cm <sup>2</sup> (lb-in-s <sup>2</sup> x10 <sup>-3</sup> )
C041A	AKD-X00306	108 (4.25)	4.57 (40.4)	12.3 (109)	1750	4.08 (9.00)	5.86 (5.19)
C041B	AKD-X00606	108 (4.25)	4.52 (40.0)	12.2 (108)	2500	4.08 (9.00)	5.86 (5.19)
C042A	AKD-X00606	108 (4.25)	8.25 (73.0)	22.2 (196)	1700	5.67 (12.5)	8.87 (7.85)
C042B	AKD-X01206	108 (4.25)	8.45 (74.8)	22.8 (202)	2500	5.67 (12.5)	8.87 (7.85)
C043A	AKD-X00606	108 (4.25)	11.1 (98.2)	30.0 (265)	1250	7.26 (16.0)	11.9 (10.5)
C043B	AKD-X01206	108 (4.25)	11.2 (99.1)	30.2 (267)	2500	7.26 (16.0)	11.9 (10.5)
C044A	AKD-X00606	108 (4.25)	13.9 (123)	37.4 (331)	1050	8.84 (19.5)	14.9 (13.2)
C044B	AKD-X01206	108 (4.25)	14.1 (125)	37.9 (335)	2150	8.84 (19.5)	14.9 (13.2)
C051A	AKD-X00606	138 (5.43)	11.7 (104)	30.2 (267)	1200	8.39 (18.5)	27.4 (24.2)
C051B	AKD-X01206	138 (5.43)	11.9 (105)	30.6 (271)	2450	8.39 (18.5)	27.4 (24.2)
C052C	AKD-X00606	138 (5.43)	16.9 (150)	43.1 (381)	950	10.7 (23.5)	35.9 (31.8)
C052D	AKD-X01206	138 (5.43)	16.5 (146)	42.3 (374)	2050	10.7 (23.5)	35.9 (31.8)
C053A	AKD-X01206	138 (5.43)	21.0 (186)	54.1 (479)	1350	13.2 (29.0)	44.3 (39.2)
C053B	AKD-X02406	138 (5.43)	20.2 (179)	50.1 (443)	2500	13.2 (29.0)	44.3 (39.2)
C054A	AKD-X01206	138 (5.43)	24.9 (220)	63.8 (565)	1200	15.4 (34.0)	52.8 (46.7)
C054B	AKD-X02406	138 (5.43)	23.8 (211)	61.2 (542)	2500	15.4 (34.0)	52.8 (46.7)
C061A	AKD-X01206	188 (7.40)	33.8 (299)	86.8 (768)	900	18.6 (41.0)	94.1 (83.2)
C061B	AKD-X02406	188 (7.40)	32.6 (288)	75.6 (669)	1950	18.6 (41.0)	94.1 (83.2)
C062C	AKD-X01206	188 (7.40)	48.4 (428)	117 (1040)	700	23.6 (52.0)	126 (112)
C062B	AKD-X02406	188 (7.40)	44.6 (395)	102 (900)	1400	23.6 (52.0)	126 (112)
C063C	AKD-X01206	188 (7.40)	61.8 (547)	157 (1380)	550	29.0 (63.0)	157 (139)
C063B	AKD-X02406	188 (7.40)	59.0 (522)	136 (1200)	1050	29.0 (63.0)	157 (139)
C091A	AKD-X02406	246 (9.68)	50.2 (444)	120 (1060)	600	27.7 (61.0)	280 (248)
C092C	AKD-X02406	246 (9.68)	102 (900)	231 (2050)	450	41.3 (91.0)	470 (416)
C093C	AKD-X02406	246 (9.68)	139 (1230)	317 (2800)	350	54.4 (120)	660 (584)
C131C	AKD-X02406	350 (13.8)	189 (1670)	395 (3500)	250	63.5 (140)	1240 (1100)
C132C	AKD-X02406	350 (13.8)	362 (3200)	818 (7240)	120	101 (223)	2250 (1990)
C133C	AKD-X02406	350 (13.8)	499 (4410)	1070 (9890)	100	132 (292)	3020 (2670)

## 400/480 Vac Systems Performance Data

Cartridge DDR Motor	AKD Servo Drive	Frame Size	Continuous Torque	Peak Torque	Maximum Speed		Weight	Inertia (Jm)
					RPM			
		mm (in)	Nm (lb-in)	Nm (lb-in)	400 Vac	480 Vac	kg (lb)	kg-cm <sup>2</sup> (lb-in-s <sup>2</sup> x10 <sup>-3</sup> )
CH041A	AKD-X00307	108 (4.25)	4.56 (40.4)	11.3 (100)	2500	2500	4.08 (9.00)	5.86 (5.19)
CH042A	AKD-X00607	108 (4.25)	8.26 (73.1)	19.0 (168)	2500	2500	5.67 (12.5)	8.87 (7.85)
CH043A	AKD-X00607	108 (4.25)	11.1 (98.2)	25.3 (224)	2250	2500	7.26 (16.0)	11.9 (10.5)
CH044A	AKD-X00607	108 (4.25)	13.9 (123)	31.6 (280)	1850	2250	8.84 (19.5)	14.9 (13.2)
CH051A	AKD-X00607	138 (5.43)	11.7 (104)	28.0 (248)	2100	2500	8.39 (18.5)	27.4 (24.2)
CH052C	AKD-X00607	138 (5.43)	16.9 (150)	43.1 (381)	1750	2100	10.7 (23.5)	35.9 (31.8)
CH053A	AKD-X01207	138 (5.43)	21.0 (186)	54.1 (479)	2350	2500	13.2 (29.0)	44.3 (39.2)
CH054A	AKD-X01207	138 (5.43)	24.9 (220)	63.8 (565)	2100	2500	15.4 (34.0)	52.8 (46.7)
CH061A	AKD-X01207	188 (7.40)	33.8 (299)	86.8 (768)	1600	1900	18.6 (41.0)	94.1 (83.2)
CH062C	AKD-X01207	188 (7.40)	48.4 (428)	117 (1040)	1250	1550	23.6 (52.0)	126 (112)
CH063C	AKD-X01207	188 (7.40)	61.8 (547)	157 (1380)	950	1150	29.0 (63.0)	157 (139)
CH063B	AKD-X02407	188 (7.40)	59.0 (522)	136 (1200)	1850	2200	29.0 (63.0)	157 (139)
CH091A	AKD-X02407	246 (9.68)	50.2 (444)	120 (1060)	1200	1500	27.7 (61.0)	280 (248)
CH092C	AKD-X02407	246 (9.68)	102 (900)	231 (2050)	800	1000	41.3 (91.0)	470 (416)
CH093C	AKD-X02407	246 (9.68)	139 (1230)	317 (2800)	700	800	54.4 (120)	660 (584)
CH131C	AKD-X02407	350 (13.8)	189 (1670)	395 (3500)	500	600	63.5 (140)	1240 (1100)
CH131B	AKD-X04807*	350 (13.8)	190 (1680)	396 (3500)	800	1000	63.5 (140)	1240 (1100)
CH132C	AKD-X02407	350 (13.8)	362 (3200)	818 (7240)	250	300	101 (223)	2250 (1990)
CH132B	AKD-X04807*	350 (13.8)	361 (3190)	759 (6720)	400	500	101 (223)	2250 (1990)
CH133C	AKD-X02407	350 (13.8)	499 (4410)	1070 (9480)	200	250	132 (292)	3020 (2670)
CH133B	AKD-X04807*	350 (13.8)	510 (4510)	1090 (9700)	350	400	132 (292)	3020 (2670)

## Cartridge DDR C09 and C13 Dimensions

Note 1: Refer to page 66 for matching cables.

Note 2: For complete AKD and Cartridge DDR motor model nomenclature, refer to pages 63 and 65 respectively.

\*Coming soon

Sold & Serviced By:

 **ELECTROMATE**

Toll Free Phone (877) SERV098

Toll Free Fax (877) SERV099

www.electromate.com

sales@electromate.com



## Cartridge DDR C04, C05 and C06 Dimensions

Cartridge DDR Motor	A mm (in)	B mm (in)	C mm (in)	D mm (in)
C(H)041	171 (6.73)	108 (4.25)	59 (2.31)	93 (3.67)
C(H)042	202 (7.95)	108 (4.25)	59 (2.31)	93 (3.67)
C(H)043	233 (9.17)	108 (4.25)	59 (2.31)	93 (3.67)
C(H)044	264 (10.4)	108 (4.25)	59 (2.31)	93 (3.67)
C(H)051	195 (7.68)	138 (5.43)	76 (3.00)	108 (4.25)
C(H)052	220 (8.66)	138 (5.43)	76 (3.00)	108 (4.25)
C(H)053	245 (9.65)	138 (5.43)	76 (3.00)	108 (4.25)
C(H)054	270 (10.6)	138 (5.43)	76 (3.00)	108 (4.25)
C(H)061	226 (8.90)	188 (7.40)	99 (3.88)	133 (5.25)
C(H)062	260 (10.2)	188 (7.40)	99 (3.88)	133 (5.25)
C(H)063	294 (11.6)	188 (7.40)	99 (3.88)	133 (5.25)

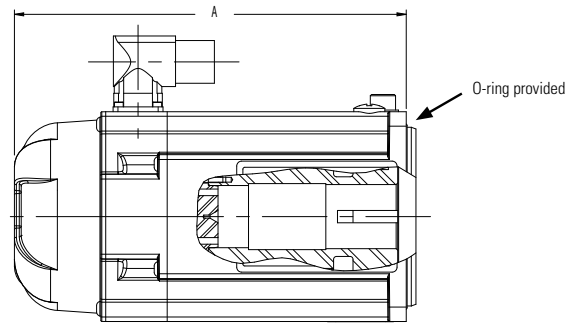
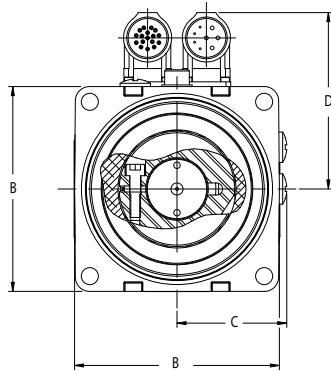

Cartridge DDR Motor	A mm (in)	B mm (in)	C mm (in)	D mm (in)
C(H)091	204 (8.03)	246 (9.68)	149 (5.88)	182 (7.18)
C(H)092	253 (9.96)	246 (9.68)	149 (5.88)	182 (7.18)
C(H)093	302 (11.9)	246 (9.68)	149 (5.88)	182 (7.18)
C(H)131	231 (9.09)	350 (13.8)	200 (7.87)	256 (10.1)
C(H)132	301 (11.9)	350 (13.8)	200 (7.87)	256 (10.1)
C(H)133	370 (14.6)	350 (13.8)	200 (7.87)	256 (10.1)

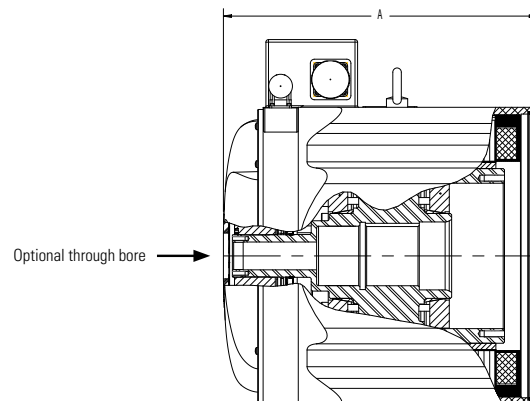
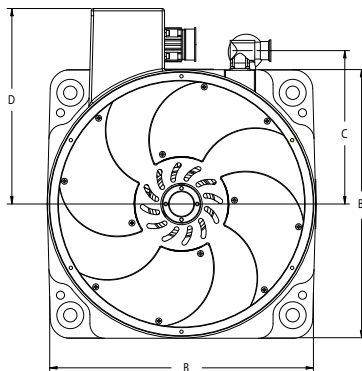

Sold &amp; Serviced By:

Toll Free Phone (877) SERV098

Toll Free Fax (877) SERV099

www.electromate.com

sales@electromate.com

# Housed Direct Drive Rotary (DDR) Motor

Housed DDR motors are multi-pole (16 to 32) hollow shaft motors with their own bearings and high-resolution encoder system. They are coupled directly to the load and enable very precise and repeatable systems. Housed DDR motors are maintenance free and run more quietly and with better dynamics than systems that use gears, belts, cams or other mechanical transmission components.

## Housed DDR Features

- 4 frame sizes
- Robust cross-roller bearing
- Dual bearing option
- IP67 option
- Continuous torque range: 5.8 Nm (4.3 lb-ft) to 339 Nm (250 lb-ft)
- Optimized torque output with high-pole count efficient electromagnetic design
- Integrated high-resolution sine-encoder
- 134,217,728 counts per rev resolution, 27 bits
- Feedback accuracy: +/- 26 arc-sec
- Repeatability better than 1 arc second

## Housed DDR Benefits

- Transmission elements such as couplings, toothed belts, spindles, and other fitted components can be eliminated
- Mechanical design is made much simpler
- Power transmission without backlash
- More compact machinery assemblies
- Increased performance for the entire system

## Housed DDR Motor Advantage

Consider how a Housed DDR motor improved a medical manufacturing machine.

Product is located at the steel pins on the outside of the machine's turret as shown. The 115 kg load wheel has an inertia of 20 kg-m<sup>2</sup>. There are 96 steel pins for an index angle of 3.5 degrees to move.

**The move is accomplished in less than 100 ms.**



## Realized Housed DDR Motor Benefits

### The Direct Drive Advantage

The following improvements were observed compared to the previous design that used a mechanical indexer:

### Improved Repeatability

The Housed DDR motor demonstrated a repeatability better than 1 arc-second which was substantially better than the mechanical indexer.

### No Degradation

Direct drive system performance, accuracy and repeatability do not degrade over time as they do with a mechanical indexer. With a mechanical indexer, as parts wear over time, the accuracy and repeatability degrade.

### Immediate Stop

The direct drive system can immediately stop if there is a process error. The mechanical indexer required several cycles to stop which could cause tooling and machine damage.

### Greatly Reduced Audible Noise

With the mechanical indexer, the noise was at a level such that two people would have to yell to hear each other. By contrast, if you turned your back to the Housed DDR motor, you could barely detect that it was running.

### Easy Profile Change

Motion parameters such as index angle, speed, acceleration, and dwell are very simple to change with the Housed DDR motor. The mechanical indexer does not support flexible motion profiles.

### Better Value

The Housed DDR motor is attractively priced compared to the mechanical indexer it replaced. When the other advantages listed above are also considered, the Housed DDR motor was the obvious choice.

### 240 Vac Performance Data

Housed DDR Motor	AKD Servo Drive	Frame Size mm (in)	Continuous Torque Nm (lb-in)	Peak Torque Nm (lb-in)	Maximum Speed (RPM)	Weight kg (lb)	Inertia (Jm) cm <sup>2</sup> (lb-in-s <sup>2</sup> x10 <sup>-3</sup> )
D061	AKD-X00606	175 (6.90)	5.3 (46.9)	16.9 (150)	500	9.4 (20.7)	61 (54.0)
D062	AKD-X00606	175 (6.90)	9.8 (86.7)	33.5 (296)	500	11.3 (24.9)	71 (62.8)
D063	AKD-X00606	175 (6.90)	17.7 (157)	64.4 (570)	500	13.8 (30.4)	86 (76.1)
D081	AKD-X00606	217 (8.55)	15.9 (141)	45.0 (398)	500	17.9 (39.4)	144 (127)
D082	AKD-X00606	217 (8.55)	25.9 (229)	92.2 (816)	300	21.5 (47.3)	194 (172)
D083	AKD-X00606	217 (8.55)	50.4 (446)	160 (1420)	250	28.8 (63.4)	301 (266)
D101	AKD-X00606	280 (11.0)	34.6 (306)	129 (1140)	300	31.5 (69.3)	693 (613)
D102	AKD-X00606	280 (11.0)	63.4 (561)	227 (2010)	200	43.8 (96.4)	992 (878)
D103	AKD-X01206	280 (11.0)	115 (1020)	501 (4430)	120	60.8 (134)	1750 (1550)
D141	AKD-X01206	362 (14.2)	108 (956)	367 (3250)	200	59.4 (131)	1630 (1440)
D142	AKD-X01206	362 (14.2)	183 (1620)	519 (4590)	120	86.6 (191)	2740 (2430)
D143	AKD-X02406	362 (14.2)	339 (3000)	1340 (11,900)	60	146 (321)	5420 (4800)

### 400/480 Vac Performance Data

Housed DDR Motor	AKD Servo Drive	Frame Size mm (in)	Continuous Torque Nm (lb-in)	Peak Torque Nm (lb-in)	Maximum Speed (RPM)	Weight kg (lb)	Inertia (Jm) cm <sup>2</sup> (lb-in-s <sup>2</sup> x10 <sup>-3</sup> )
DH061	AKD-X00607	175 (6.90)	5.3 (46.9)	16.9 (150)	800	9.4 (20.7)	61 (54.0)
DH062	AKD-X00607	175 (6.90)	9.8 (86.7)	33.5 (296)	800	11.3 (24.9)	71 (62.8)
DH063	AKD-X00607	175 (6.90)	17.7 (157)	64.4 (570)	800	13.8 (30.4)	86 (76.1)
DH081	AKD-X00607	217 (8.55)	15.9 (141)	45.0 (398)	500	17.9 (39.4)	144 (127)
DH082	AKD-X00607	217 (8.55)	25.9 (229)	92.2 (816)	500	21.5 (47.3)	194 (172)
DH083	AKD-X00607	217 (8.55)	50.4 (446)	160 (1420)	500	28.8 (63.4)	301 (266)
DH101	AKD-X00607	280 (11.0)	34.6 (306)	129 (1140)	300	31.5 (69.3)	693 (613)
DH102	AKD-X00607	280 (11.0)	63.4 (561)	227 (2010)	300	43.8 (96.4)	992 (878)
DH103	AKD-X01207	280 (11.0)	115 (1020)	501 (4430)	250	60.8 (134)	1750 (1550)
DH141	AKD-X01207	362 (14.2)	108 (956)	367 (3250)	300	59.4 (131)	1630 (1440)
DH142	AKD-X01207	362 (14.2)	183 (1620)	519 (4590)	300	86.6 (191)	2740 (2430)
DH143	AKD-X02407	362 (14.2)	339 (3000)	1340 (11,900)	120	146.0 (321)	5420 (4800)

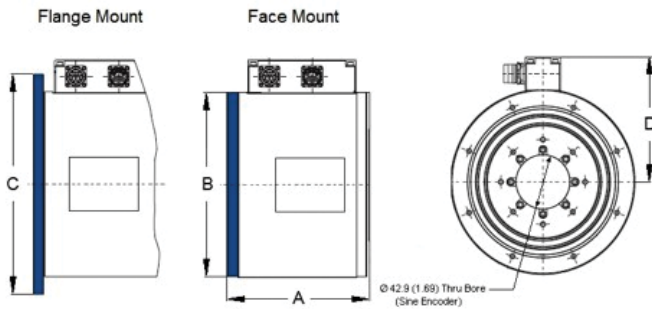

### Dimensions

DDR	A mm (in)	B mm (in)	C mm (in)	D mm (in)
D(H)061	130 (5.12)	175 (6.90)	220 (8.66)	126 (4.95)
D(H)062	140 (5.55)	175 (6.90)	220 (8.66)	126 (4.95)
D(H)063	164 (6.46)	175 (6.90)	220 (8.66)	126 (4.95)
D(H)081	145 (5.71)	217 (8.55)	260 (10.2)	147 (5.80)
D(H)082	165 (6.50)	217 (8.55)	260 (10.2)	147 (5.80)
D(H)083	206 (8.11)	217 (8.55)	260 (10.2)	147 (5.80)
D(H)101	153 (6.02)	280 (11.0)	330 (13.0)	181 (7.11)
D(H)102	185 (7.28)	280 (11.0)	330 (13.0)	181 (7.11)
D(H)103	248 (9.76)	280 (11.0)	330 (13.0)	181 (7.11)
D(H)141	153 (6.02)	362 (14.2)	406 (16.0)	218 (8.59)
D(H)142	217 (8.52)	362 (14.2)	406 (16.0)	218 (8.59)
D(H)143	344 (13.50)	362 (14.2)	406 (16.0)	218 (8.59)

Note 1: Refer to page 66 for matching cables.

Note 2: For complete AKD and Housed DDR motor model nomenclature, refer to pages 67 and 70 respectively.

# Linear Positioning System

Kollmorgen is also the market leader in precise linear positioning, backed by 40 years of experience of providing innovative solutions customers can count on everyday. We offer linear positioners that range from 20 N (5 lb) of thrust and 100 mm (4 in) length, up to 25 kN (5600 lb) and 1.5 m length (unlimited length for linear motors) with precision better than a single thread of human hair ( $\leq 0.1$  mm/0.004 in). Our linear positioner families leverage the breadth of our AKM servomotor product line, which provides a wide range of solutions for nearly any application.

## Electric Cylinders (EC)

Primarily designed to apply a force through an extendable rod, electric cylinders are a clean and efficient replacement for hydraulic actuators and pneumatic cylinders, and an alternative to many types of linear transmissions. A wide variety of mounting and coupling alternatives significantly increases their problem solving potential.

## Rodless Actuators

Long travel, quiet operation, and high moment loading differentiates rodless actuators from other mechanical transmissions.

## Precision Tables

Positioning tables are used when accurate and repeatable motion is critical (1 part per 10,000 or better). These tables offer a wide variety of single and multi-axis configurations, open and closed frame tables, ball or lead screw driven, and overhung and constant support for Kollmorgen geometry configurations.

## Direct Drive Linear (DDL) Motor

Directly coupling a linear motor to the driven load offers many advantages, including eliminating all mechanical transmissions, such as ball/lead screws, rack & pinions, belts/pulleys, and eliminating gearboxes. This in turn also eliminates backlash and compliance, and other problems associated with these mechanical transmissions.

## DDL Benefits

- Zero maintenance
- No ball screws, gearboxes, rack and pinions, belts/pulleys
- Zero backlash and compliance
- High stiffness
- High positional accuracy
- Compact mechanical assembly
- Reduced parts count in machine
- Very smooth velocity
- Quiet operation



Electric Cylinders



Rodless Actuators



Precision Tables

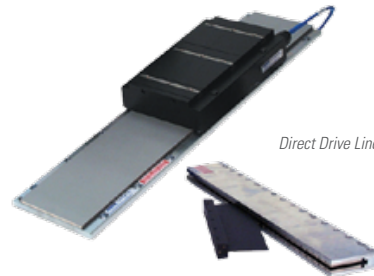

Direct Drive Linear Motors

**Performance Data**

	Minimum Stroke mm (in)	Maximum Stroke mm (in)	Repeatability mm (in)	Maximum Thrust kN (lbf)	Maximum Payload kN (lbf)	Maximum Speed mm/s (in/s)
Electric cylinders	50 (2.0)	1500 (60)	0.013 (0.0005)	25 (5620)	Designed to push and pull	1300 (51)
Rodless actuators	150 (6.0)	2700 (106)	0.1 (0.004)	3.1 (700)	1.33 (300)	3000 (120)
Precision tables	50 (2.0)	1500 (60)	0.004 (0.00016)	2.0 (440)	6.2 (1400)	1300 (51)
Direct drive linear motors*	64 (2.5)	Unlimited	$1 \times 10^{-6}$ ( $3.9 \times 10^{-8}$ )	15.6 (3500)	Customer design limited	5000 (200)

\* We offer hundreds of custom and semi-custom solutions for direct drive linear (DDL) applications.

Sold & Serviced By:

 **ELECTROMATE**

Toll Free Phone (877) SERV098

Toll Free Fax (877) SERV099

[www.electromate.com](http://www.electromate.com)

[sales@electromate.com](mailto:sales@electromate.com)

# Precision Tables DS4 / DS6 Series

Precision positioning tables are best suited for applications where the accuracy and repeatability requirements are more important than axial thrust of the drive train. Precision positioning tables can also be used in less precise applications where adequate moment load support is necessary, and are ideal building blocks for complete multi-axis positioning systems.

The DS4 and DS6 are Kollmorgen's most versatile and modular line of positioning tables.

## Combined with the AKD Servo Drive and AKM Servomotors, DS4 and DS6 Systems Offer

- An optimized electromechanical solution suitable for demanding high precision positioning
- Performance and versatility in a compact package
- Outstanding industrial durability
- Tremendous configuration flexibility
- Industry-leading price vs. performance value



## DS Series Design Features

Following are several features that make the DS Series the positioning table of choice for the most demanding applications:

- Travel lengths from 50 mm to 2 m cover a wide range of applications.
- Precision ballscrew drive, with 5 mm, 10 mm and 25 mm leads, offers high speed and efficiency, excellent repeatability and accuracy, and mechanical advantage.
- Proven magnetic stainless steel seal strip technology effectively seals the internal components of the DS Series, protecting the ballscrew and ways from contaminants. This feature also contains ballscrew and way lubrication within the DS Series.
- Easily configurable modular design and option set, including a variety of motor mounting orientations, motor sizes and type, ballscrew leads, coupling types and sizes, encoder feedback options, limit/home sensor types, and shaft brakes allow the DS Series to be customized to meet your specific requirements.

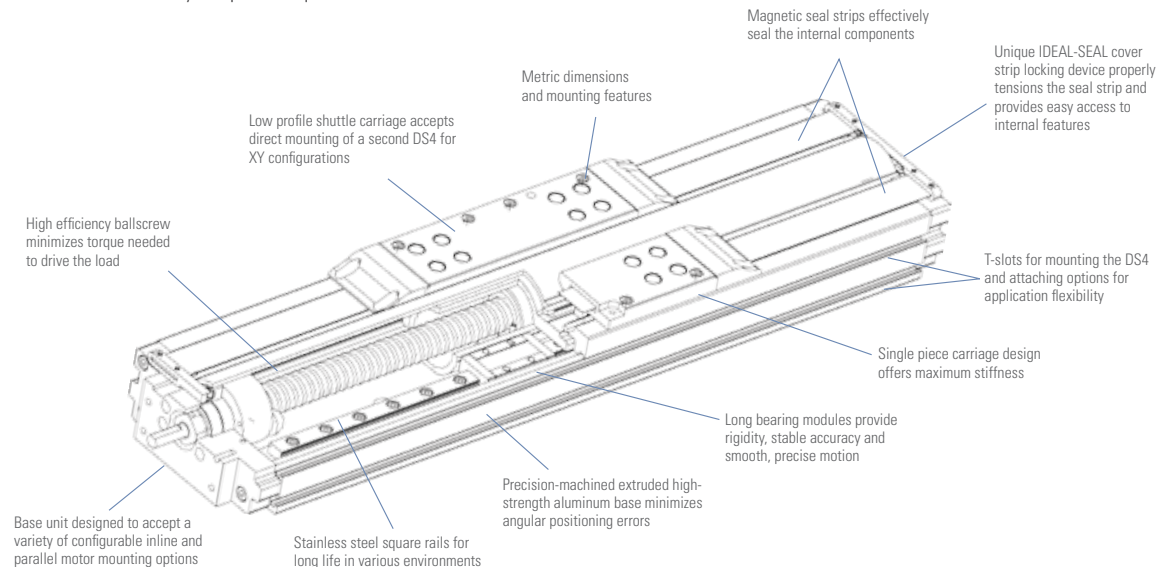

Sold & Serviced By:

 **ELECTROMATE**

Toll Free Phone (877) SERV098

Toll Free Fax (877) SERV099

[www.electromate.com](http://www.electromate.com)

[sales@electromate.com](mailto:sales@electromate.com)

DS Series precision tables can be ordered in a variety of multi-axis configurations including XY, XZ, and XYZ or cartesian arrangements. Consult Kollmorgen applications engineering for standard and custom configurations.

A second option is to order standard multi-axis brackets and assemble the axes yourself.



All DS4 and DS6 tables will bolt directly together in a standard XY without modification.

### Unique IDEAL-SEAL Magnetic Cover Strip Locking Device

- Entire length of lead screw and linear bearing system are protected, providing both operator safety and protection from contaminants.
- Seal strips are always properly tensioned, drastically decreasing wear that requires regular field repair.
- Allows easy access to interior of DS4 for mounting and maintenance.
- No small hardware or springs to lose, and no exposure to the sharp ends of the strips, which are problems for similar seal end-cap designs.

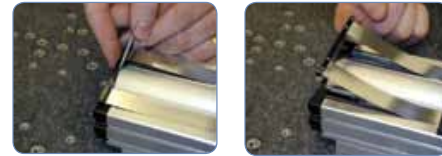

### Configurable Options

DS Series	
Servomotor options	AKM23D, AKM42G
Grades	Precision* (up to 600 mm), commercial
Motor orientations	In-line, parallel right/left/under
Couplings options** (in-line configurations)	Bellows
Transmission ratio (parallel configurations)	1:1
Limit sensors	PNP (sinking) inductive proximity sensors, 5-30 Vdc
Home sensor	PNP (sinking) inductive proximity sensors, 5-30 Vdc
Shaft brake	Electromagnetic power of holding brake, 24 Vdc
Linear encoder options	1.0, 0.5 and 0.1 motion resolution, modular incremental type

\* Additional lead time applies to precision grade. Contact customer support for details.

\*\* Additional couplings available. Contact customer support for details.



Limit Sensor



Linear Encoder



Toe Clamp

### Accessories

DS Series	
Toe clamps	Provide convenient external mounting to a base plate or to riser blocks
Narrow riser blocks	Raise unit for clearance of larger motor options, utilizing internal base mounting features on the side
Wide riser blocks	Allow rising of the unit, independent of base mounting features
Brackets and mounting plates	Facilitate multi-axis configurations
Cable sets	For connection to AKD and other drives

Sold & Serviced By:



Toll Free Phone (877) SERV098

Toll Free Fax (877) SERV099

www.electromate.com

sales@electromate.com

# Precision Tables DS4 / DS6 Series

## DS4 General Specifications

Travel (mm)	50	100	150	200	250	300	350	400	450	500	550	600	
Overall height, less motor (mm)	47												
Width (mm)	95												
System length, Inline less motor (mm)	317	367	417	467	517	567	617	667	717	767	817	867	
System length, parallel motor mounts (mm)	300	350	400	450	500	550	600	650	700	750	800	850	
Positional accuracy (microns)													
Commercial grade	12	12	14	20	22	24	26	26	28	34	36	40	
Precision grade	8	8	10	12	12	14	14	16	19	21	23	25	
Straightness & flatness (microns)	6	6	9	12	12	14	18	21	23	23	25	25	
Bi-directional repeatability, open loop													
Commercial grade (microns)	+/- 3												
Precision grade (microns)	+/- 1.3												
Load capacity, normal (kg) (max)	170												
Axial load capacity (kg)	90												
Acceleration (max) (m/sec <sup>2</sup> )	20												
Moving mass (kg)	0.75												
Total mass (kg)	2.7	3	3.3	3.6	3.9	4.1	4.4	4.7	5	5.3	5.6	5.9	
Ballscrew diameter (mm)	16												
Duty cycle (%)	100												
Ballscrew efficiency	90												
Max. breakaway torque (oz-in)	18												
Max. running torque (oz-in)	16												
Ballscrew lead available (mm)	5, 10												
Input inertia (10 <sup>-5</sup> kg-m <sup>2</sup> )	1.17	1.24	1.67	1.93	2.18	2.43	2.68	2.93	3.19	3.44	3.69	3.94	
Max. ballscrew speed (rev/sec)	80				60				55		50		

## DS6 General Specifications

Travel (mm)	100	200	300	400	500	600	700	800	900	1000	1250	1500	1750	2000										
Overall height (mm)	70																							
Width (mm)	150																							
System length, inline less motor (mm)	465	565	665	765	865	965	1065	1165	1265	1365	1615	1865	2115	2365										
System length, parallel motor mounts (mm)	470	570	670	770	870	970	1070	1170	1270	1370	1620	1870	2120	2370										
Positional accuracy (microns)																								
Commercial grade	14	22	28	39	45	48	92	94	103	105	118	134	154	159										
Precision grade	12	14	15	20	25	50	-	-	-	-	-	-	-	-										
Straightness & flatness (microns)	10	14	17	23	30	33	40	46	50	55	76	95	115	135										
Bi-directional repeatability, open loop																								
Commercial grade (microns)	+/- 3						+/-5																	
Precision grade (microns)	+/- 1.3						N/A																	
Load capacity, normal (kg) (max)	630																							
Axial load capacity (kg)																								
Commercial grade	90						200																	
Precision grade	90						N/A																	
Acceleration (max) (m/sec <sup>2</sup> )	20																							
Moving mass (kg)	2.8																							
Total mass (kg)	8.9	10.2	11.5	12.8	14.0	15.4	19.4	20.9	22.4	23.9	27.8	31.6	35.4	40.1										
Ballscrew diameter (mm)	16						25																	
Duty cycle (%)	100																							
Ballscrew efficiency	90						80																	
Max. breakaway torque (oz-in)	18						55																	
Max. running torque (oz-in)	16						48																	
Ballscrew lead available (mm)	5, 10						5, 10, 25																	
Input inertia (10 <sup>-5</sup> kg-m <sup>2</sup> )	3.8	4.4	5	5.5	6.1	6.7	37	40.4	43.9	47.3	56	64.5	73.2	81.9										
Max. ballscrew speed (rev/sec)	80			60			50		60		50		40		35		24		16		13		11	

\*All performance specifications are based upon proper mounting procedures, with the DS table fully supported on a flat surface (flat within 0.008 mm/300 mm). Positional accuracy and repeatability specifications are for inline motor mount models only. Contact customer support for specifications of parallel mount configurations. Above specifications are measured 37.5 mm directly above the center of the carriage. Specifications are based upon operation at 20° C.

Sold & Serviced By:

 **ELECTROMATE**

Toll Free Phone (877) SERV098

Toll Free Fax (877) SERV099

[www.electromate.com](http://www.electromate.com)

[sales@electromate.com](mailto:sales@electromate.com)



### 120 Vac Performance Data

	Sys #	Precision Table - AKM Servomotor	AKD Servo Drive	Stroke Length Type	Cont. Thrust @ Speed (lb @ in/sec)		Peak Thrust @ Speed (lb @ in/sec)		Max Thrust (lb)	Max System Speed (in/sec)	Max Stroke for Max Speed (mm)
DS4	1	DS4-XXX-10G-AKM23D-■■■■	AKD-X00306	≤ 600 mm	104	17.6	210	10.8	210	17.6	600
	2	DS4-XXX- 5G-AKM23D-■■■■	AKD-X00306	≤ 600 mm	195	8.8	210	8.4	210	8.8	600
DS6	3	DS6-XXX-25G-AKM23D-■■■■	AKD-X00306	≤ 600 mm	37	44.0	138	8.2	138	44.0	600
	4	DS6-XXX-10G-AKM23D-■■■■	AKD-X00306	≤ 600 mm	104	17.6	210	12.4	210	17.6	600
	5	DS6-XXX- 5G-AKM23D-■■■■	AKD-X00306	≤ 600 mm	195	8.8	210	8.6	210	8.8	600
DS6	6	DS6-XXX-25G-AKM23D-■■■■	AKD-X00306	≥ 700 mm	41	44.0	138	8.2	154	44.0	800
	7	DS6-XXX-10G-AKM23D-■■■■	AKD-X00306	≥ 700 mm	91	17.6	331	3.1	376	17.6	800
	8	DS6-XXX- 5G-AKM23D-■■■■	AKD-X00306	≥ 700 mm	143	8.8	440	5.0	440	8.8	800

### 240 Vac Performance Data

	Sys #	Precision Table - AKM Servomotor	AKD Servo Drive	Stroke Length Type	Cont. Thrust @ Speed (lb @ in/sec)		Peak Thrust @ Speed (lb @ in/sec)		Max Thrust (lb)	Max System Speed (in/sec)	Max Stroke for Max Speed (mm)
DS4	1	DS4-XXX-10G-AKM23D-■■■■	AKD-X00306	≤ 600 mm	98	31.5	210	31.5	210	31.5	300
	2	DS4-XXX- 5G-AKM23D-■■■■	AKD-X00306	≤ 600 mm	184	15.7	210	15.7	210	15.7	300
DS6	3	DS6-XXX-10G-AKM23D-■■■■	AKD-X00306	≤ 600 mm	98	31.5	210	31.5	210	31.5	300
	4	DS6-XXX- 5G-AKM23D-■■■■	AKD-X00306	≤ 600 mm	184	15.7	210	15.7	210	15.7	300
	5	DS6-XXX-25G-AKM23D-■■■■	AKD-X00306	≥ 700 mm	40	59	154	47	154	59	700
	6	DS6-XXX-10G-AKM23D-■■■■	AKD-X00306	≥ 700 mm	88	23.6	374	18	374	23.6	700
	7	DS6-XXX- 5G-AKM23D-■■■■	AKD-X00306	≥ 700 mm	138	11.8	440	11.8	440	11.8	700
	8	DS6-XXX-10G-AKM42G-■■■■	AKD-X00306	≤ 600 mm	210	28.4	210	28.4	210	28.4	300
	9	DS6-XXX- 5G-AKM42G-■■■■	AKD-X00306	≤ 600 mm	210	14.5	210	14.5	210	14.5	300
	10	DS6-XXX-25G-AKM42G-■■■■	AKD-X00306	≥ 700 mm	114	59	438	35.8	438	59	700
	11	DS6-XXX-10G-AKM42G-■■■■	AKD-X00306	≥ 700 mm	272	23.6	440	23.6	440	23.6	700
	12	DS6-XXX- 5G-AKM42G-■■■■	AKD-X00306	≥ 700 mm	440	11.8	440	11.8	440	11.8	700

Note 1: Performance based on inline motor configuration.

Note 2: Refer to page 66 for matching cables.

Note 3: For complete AKD and DS4 / DS6 Series model nomenclature, refer to pages 67 and 71 respectively.

# Electric Cylinders N2 / EC Series

Electric cylinders are thrust-producing devices that are best suited for applications requiring high axial force with the moment and side loads already properly supported.

Kollmorgen has combined the broad product offering of the N2 and EC Series electric cylinders with the industry-leading AKM servomotors and AKD servo drives. The N2 and EC Series of electric cylinders offer a wide range of available thrusts in standard units from 600 lb (N2) to 5620 lb (EC5) across 5 electric cylinder frame sizes.

- Speeds up to 52 in/sec are available and integrated geared options provide the ability to increase thrust capacity for lower speed applications, leveraging the speed capacity of servo systems.
- Multiple servomotor options are available for the product line ranging from NEMA 23 size to NEMA 42 size servos. The combination with the AKM servomotor enables the use of various feedback devices including sine-encoder and the low-cost but high-performance Smart Feedback Device (SFD) when used with the AKD servo drive.
- Windings and voltage operation are not differentiated in MOTIONEERING®. All systems are offered at all voltages (240, 400, 480).
- The AKM servomotor comes mounted on the electric cylinder as specified by the electric cylinder part number. This eliminates time to match the motor to the electric cylinder and eliminates potential mechanical incompatibility.

## EC Servo Positioners

- Designed for performance
- Highest quality precision rolled ballscrews and Acme screws – for quiet, long-life operation
- Brushless servo with encoder, resolver or SFD feedback
- Sealed for IP54 protection. IP65 option available
- Thrust up to 25,000 N [5,620 lb]
- Speed up to 1.3 m/s [52.5 in/sec]
- Metric design (ISO 6431)
- Available in 5 power ranges – EC1, 2, 3, 4 & 5

## N2 Servo Positioners

- Smallest package size
- Time-proven design
- Improved durability over previous designs
- Thrust up to 2,670 N [600 lb]
- Speed up to 0.76 m/s [30 in/sec]
- English dimensions (to NFPA standards)
- Brushless servo with encoder, resolver or SFD feedback

## Typical Construction (EC2 cut-away shown)

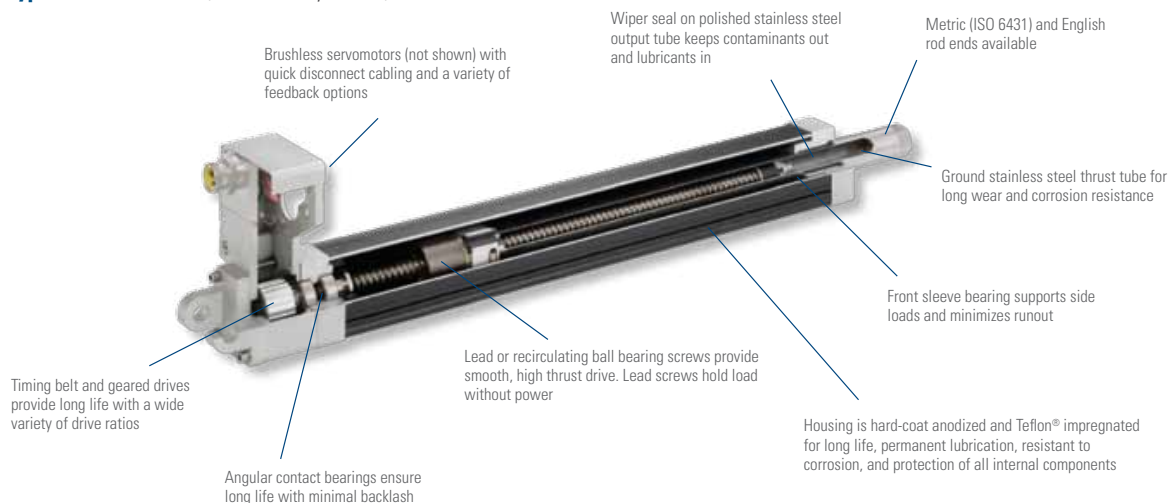

Sold & Serviced By:

 **ELECTROMATE**

Toll Free Phone (877) SERV098

Toll Free Fax (877) SERV099

[www.electromate.com](http://www.electromate.com)

[sales@electromate.com](mailto:sales@electromate.com)

**Kollmorgen offers electric cylinder drive mechanisms designed around either lead or ballscrews.** Ballscrews, being the more efficient of the two, utilize ball nuts riding on recirculating ball bearings, resulting in higher speeds, loads and cycle rates. However, the more efficient design of ballscrew technology lends it to being backdriven when power is removed if precautions are not taken (e.g., electric brakes or counter loading).

Lead screws are capable of holding the load in position when power is removed, but are less efficient in operation. Kollmorgen's guide system prevents rotation of the drive nut, thus eliminating any torque loading to machine linkage.

### Electric Cylinders Are Preferred When:

- Positioning an externally guided and supported load
- Moving a load that pivots
- There is a high concentration of airborne contaminants (rodless actuators are inherently less well protected)
- Replacing a hydraulic or pneumatic cylinder with an electromechanical solution



### General Specifications

Series	N2		EC1	EC2		EC3		EC4	EC5
Std. maximum stroke length inches (mm)	* 22.5 (571.5)		7.87 (200)	29.53 (750)		39.37 (1000)		59.06 (1500)	59.06 (1500)
Type of screw	Lead	Ball	Ball	Lead	Ball	Lead	Ball	Ball	Ball
Lead	0.2 in, 0.5 in	0.2 in, 0.5 in	1.025 in	4 mm	16, 5 mm	4 mm	16, 10, 5 mm	25, 10 mm	32, 10 mm
Nom. lead screw diameter	0.625 in	0.625 in	0.375 in	16 mm	16 mm	20 mm	20 mm	25 mm	32 mm
Backlash inches (mm)	0.016 (0.40)	0.015 (0.38)	0.015 (0.30)	0.016 (0.40)	0.010 (0.25)	0.016 (0.40)	0.010 (0.25)	0.12 (0.30)	0.12 (0.30)
Dimension Std.	English NFPA Std.		Metric ISO 6431 Std.	Metric ISO 6431 Std.		Metric ISO 6431 Std.		Metric ISO 6431 Std.	Metric ISO 6431 Std.
Bore size (mm)			0.875 in	50		63		80	100
Brushless servomotor	AKM23, NEMA 23		AKM1x, NEMA 17	AKM23, NEMA 23		AKM23, NEMA 23 AKM42, NEMA 34 AKM52, NEMA 42 **		AKM42, NEMA 34 AKM52, NEMA 42 **	AKM42, NEMA 34 AKM52, NEMA 42 **
Max. thrust lb. (N)	600 (2670)		150 (667)	810 (3600)		1620 (7200)		2700 (12,000)	5620 (25,000)
Max. velocity in/sec (m/s)	12 (0.3)	30 (0.76)	13 (0.33)	9.2 (0.23)	50 (1.27)	8.0 (0.20)	50 (1.28)	52.5 (1.33)	52.5 (1.33)
Max. rated duty cycle % (load, speed dependent)	50	100	100	50	100	50	100	100	100
Limit switches	optional		optional	optional		optional		optional	optional
Std. operating temperature range C (F)	32 to 140 (0 to 60)		-30 to +70 (-22 to 158)	-30 to +70 (-22 to 158)		-30 to +70 (-22 to 158)		-30 to +70 (-22 to 158)	-30 to +70 (-22 to 158)
Moisture/contaminants	Humid, but Not Direct Contact		IP54 Std. IP65 Opt.	IP54 Std. IP65 Opt.		IP54 Std. IP65 Opt.		IP54 Std. IP65 Opt.	IP54 Std. IP65 Opt.

\* Requires dual rod-end bearing option for length over 12".

\*\* NEMA 42 mount, shaft does not follow a NEMA std.

Sold & Serviced By:

**ELECTROMATE**

Toll Free Phone (877) SERV098

Toll Free Fax (877) SERV099

www.electromate.com

sales@electromate.com

# Electric Cylinders N2 / EC Series

AKD SERVO SYSTEMS

ELECTRIC CYLINDERS N2/EC SERIES

## N2 MF1 Front Rectangular Flange Mount

Parallel

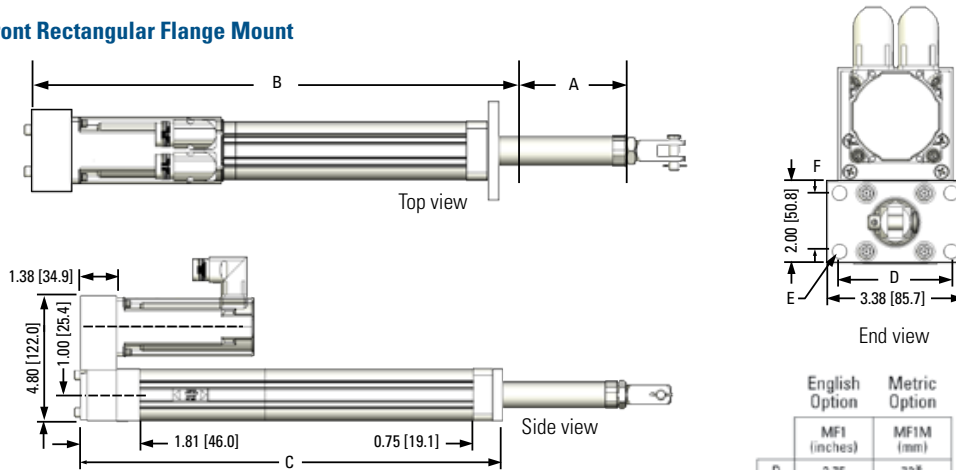

	English Option	Metric Option
D	2.75	72*
E	0.34	9*
F	1.43	36*

\* Meets ISO 40mm bore standard

## N2 Series Dimensions

A	Standard Stroke Lengths Available						
inch	2.0	4.0	6.0	8.0	12.0	18.0	24.0
mm	50.8	101.6	152.4	203.2	304.8	457.2	609.6

B	Retract Length	C	Mounting length
inch	5.37 + S	inch	5.06 + S
mm	136.4 + S	mm	128.5 + S

S = stroke

## EC MF1 Front Flange

Parallel

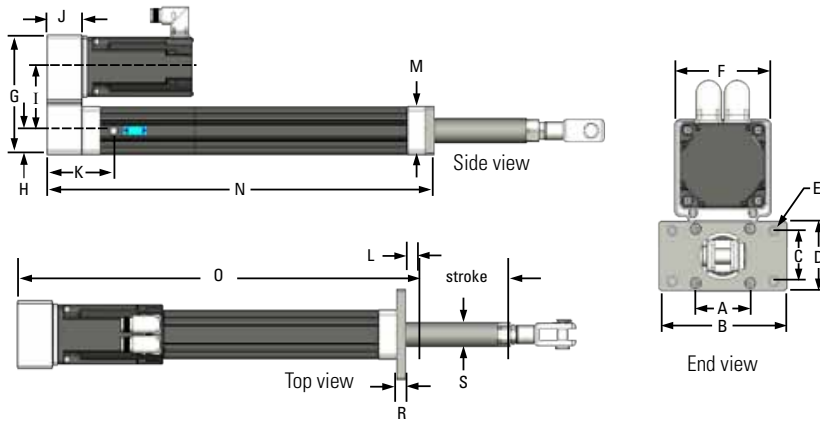

## Flange Dimensions

In accordance with ISO 6431 for:	
Type	Bore Size
EC1	30 mm
EC2	50 mm
EC3	63 mm
EC4	80 mm
EC5	100 mm

Sold & Serviced By:

ELECTROMATE

Toll Free Phone (877) SERV098

Toll Free Fax (877) SERV099

www.electromate.com

sales@electromate.com

## EC Series Dimensions

	A	B	C	D	E	F	G	H
	mm (inch)	mm (inch)	mm (inch)	mm (inch)	mm (inch)	mm (inch)	mm (inch)	mm (inch)
EC1	60.0 (2.36)	74.0 (2.91)	28.0 (1.10)	40.0 (1.57)	6.60 (0.26)	48.0 (1.89)	82.6 (3.25)	19.0 (0.75)
EC2	90.0 (3.54)	114.3 (4.50)	45.0 (1.77)	63.5 (2.50)	9.0 (0.35)	79.8 (3.14)	144.0 (5.7)	28.4 (1.12)
EC3	100.0 (3.94)	127.0 (5.00)	50.0 (1.97)	69.1 (2.72)	9.0 (0.35)	95.5 (3.76)	169.7 (6.7)	34.8 (1.37)
EC4	127.0 (5.00)	152.4 (6.00)	69.9 (2.75)	96.3 (3.79)	13.5 (0.53)	127.0 (5.00)	221.0 (8.7)	46.1 (1.81)
EC5	150.0 (5.91)	186.9 (7.36)	75.0 (2.95)	114.3 (4.50)	13.97/14.35 (.555/.565)	127.0 (5.00)	221.0 (8.7)	46.1 (1.81)

	I	J	K	L	M	N Cyl Length	O Retract length
	mm (inch)	mm (inch)	mm (inch)	mm (inch)	mm (inch)	mm (inch)	mm (inch)
EC1	41.8 (1.65)	31.3 (1.23)	-	10.2 (0.40)	38.1 (1.50)	106.8 + S (4.2 + S)	117.0 + S (4.60 + S)
EC2	74.7 (2.94)	41.7 (1.64)	88.6 (3.49)	25.0 (0.98)	56.9 (2.24)	218.5 + S (8.6 + S)	243.4 + S (9.58 + S)
EC3	*87.6/89.7 (*3.45/3.53)	49.3 (1.94)	94.2 (3.71)	25.0 (0.98)	69.6 (2.74)	246.3 + S (9.7 + S)	271.1 + S (10.67 + S)
EC4	111.1 (4.37)	71.9 (2.83)	150.9 (5.94)	41.4 (1.63)	92.2 (3.63)	365.8 + S (14.4 + S)	406.9 + S (16.02 + S)
EC5	111.1 (4.37)	71.9 (2.83)	150.9 (5.94)	35.0 (1.38)	92.2 (3.63)	365.8 + S (14.4 + S)	406.9 + S (16.02 + S)

	P Breather port Hex		Q	R	S
	type	mm (inch)			
EC1	-	-	-	10.0 (0.39)	22.2 (0.88)
EC2	1/8 NPT	11.1 (0.44)	34.8 (1.37)	9.5 (0.37)	28.0 (1.10)
EC3	1/8 NPT	11.1 (0.44)	41.1 (1.62)	12.7 (0.50)	35.0 (1.38)
EC4	1/4 NPT	14.0 (0.55)	52.8 (2.08)	12.7 (0.50)	50.0 (1.97)
EC5	1/4 NPT	14.0 (0.55)	52.8 (2.08)	19.1 (0.75)	50.0 (1.97)

\* AKM23 / AKM24 dimension.

## 240 Vac Performance Data

Sys #	Electric Cylinder - AKM Servomotor	AKD Servo Drive	Cont. Thrust @ Speed (lb @ in/sec)		Peak Thrust @ Speed (lb @ in/sec)		Max Thrust (lb)	Max System Speed (in/sec)	**Max Stroke for Max Speed (mm)
N2	1 N2-AKM23D-■■■■-10-5B *	AKD-X00306	190	12.0	600	11.5	600	12.0	18.0
	2 N2-AKM23D-■■■■-15-5B	AKD-X00306	287	8.0	600	8.0	600	8.0	18.0
	3 N2-AKM23D-■■■■-20-5B	AKD-X00306	382	6.0	600	6.0	600	6.0	18.0
	4 N2-AKM23D-■■■■-25-5B	AKD-X00306	370	4.8	600	4.8	600	4.8	18.0
	5 N2-AKM23D-■■■■-120-5B	AKD-X00306	600	1.0	600	1.0	600	1.0	18.0
	6 N2-AKM23D-■■■■-10-2B *	AKD-X00306	75	30.0	275	24.5	280	30.0	18.0
	7 N2-AKM23D-■■■■-15-2B	AKD-X00306	115	20.0	412	16.4	421	20.0	18.0
	8 N2-AKM23D-■■■■-20-2B	AKD-X00306	152	15.0	545	12.3	545	15.0	18.0
	9 N2-AKM23D-■■■■-25-2B	AKD-X00306	146	12.0	534	9.8	545	12.0	18.0
	10 N2-AKM23D-■■■■-120-2B	AKD-X00306	600	2.5	600	2.5	600	2.5	18.0
	11 N2-AKM23D-■■■■-10-5A	AKD-X00306	86	12.0	305	9.8	312	12.0	18.0
	12 N2-AKM23D-■■■■-15-5A	AKD-X00306	128	8.0	458	6.5	467	8.0	18.0
	13 N2-AKM23D-■■■■-20-5A	AKD-X00306	169	6.0	600	4.9	600	6.0	18.0
	14 N2-AKM23D-■■■■-25-5A	AKD-X00306	165	4.8	593	3.9	600	4.8	18.0
	15 N2-AKM23D-■■■■-120-5A	AKD-X00306	600	1.0	600	1.0	600	1.0	18.0

Sys #	Electric Cylinder - AKM Servomotor	AKD Servo Drive	Cont. Thrust @ Speed (lb @ in/sec)		Peak Thrust @ Speed (lb @ in/sec)		Max Thrust (lb)	Max System Speed (in/sec)	**Max Stroke for Max Speed (mm)
EC1	1 EC1-AKM11B-■■■■-10-03B *	AKD-X00306	50	13.0	75	13.0	75	13.0	200
	2 EC1-AKM11B-■■■■-20-03B	AKD-X00306	100	6.0	125	6.0	125	6.0	200
	3 EC1-AKM11B-■■■■-40-03B	AKD-X00306	150	3.0	150	3.0	150	3.0	200
	4 EC1-AKM13C-■■■■-10-03B*	AKD-X00306	75	11.5	75	13.0	75	13.0	200
	5 EC1-AKM13C-■■■■-20-03B	AKD-X00306	125	5.9	125	6.0	126	6.0	200

## 36 Vdc Stepper Performance Data

Sys #	Electric Cylinder - CT Step Motor	Cont. Thrust @ Speed (lb @ in/sec)		Max Thrust (lb)	Max System Speed (in/sec)	**Max Stroke for Max Speed (mm)
1	EC1-CTP12XLF10-10-03B	19.7	5.0	75	5.0	200
2	EC1-CTP12XLF10-20-03B	35.4	2.5	125	2.5	200
3	EC1-CTP12XLF10-40-03B	70.8	1.25	150	1.25	200

Note 1: Refer to page 66 for matching cables.

Note 2: For complete AKD, EC, and N2 Series model nomenclature, refer to pages 67, 73 and 74, respectively.

\* Inline type with 1-to-1 gear ratio (-10L) provide 10% additional thrust (not to exceed the max thrust).

\*\* Based on critical speed of screw specification.

Sold & Serviced By:

 ELECTROMATE

Toll Free Phone (877) SERV098

Toll Free Fax (877) SERV099

www.electromate.com

sales@electromate.com

# Electric Cylinders N2 / EC Series

AKD SERVO SYSTEMS

ELECTRIC CYLINDERS N2/EC SERIES

## 240 Vac Performance Data

Sys #	Electric Cylinder - AKM Servomotor	AKD Servo Drive	Cont. Thrust @ Speed (lb @ in/sec)		Peak Thrust @ Speed (lb @ in/sec)		Max Thrust (lb)	Max System Speed (in/sec)	Max Stroke for Max Speed (mm)**	Cylinder Bore Size (EC)		
EC2	16	EC2-AKM23D-■■■■-10-04A *	AKD-X00306	108	9.2	387	7.7	396	9.2	200	50	
	17	EC2-AKM23D-■■■■-15-04A	AKD-X00306	160	6.2	521	5.8	582	6.2	300	50	
	18	EC2-AKM23D-■■■■-20-04A	AKD-X00306	216	4.6	455	4.6	622	4.6	450	50	
	19	EC2-AKM23D-■■■■-50-04A	AKD-X00306	517	1.8	809	1.8	809	1.8	600	50	
	20	EC2-AKM23D-■■■■-100-04A	AKD-X00306	809	0.9	809	0.9	809	0.9	750	50	
	21	EC2-AKM23D-■■■■-10-16B *	AKD-X00306	60	50.5	218	30.9	223	50.5	200	50	
	22	EC2-AKM23D-■■■■-15-16B	AKD-X00306	85	40.1	293	23.4	237	45.0	200	50	
	23	EC2-AKM23D-■■■■-20-16B	AKD-X00306	116	29.5	245	24.5	350	31.0	300	50	
	24	EC2-AKM23D-■■■■-50-16B	AKD-X00306	292	7.3	809	7.3	809	7.3	750	50	
	25	EC2-AKM23D-■■■■-100-16B	AKD-X00306	581	3.7	809	3.7	809	3.7	750	50	
	21	EC2-AKM23D-■■■■-10-05B *	AKD-X00306	186	16.3	697	9.7	712	16.3	200	50	
	22	EC2-AKM23D-■■■■-15-05B	AKD-X00306	272	12.5	809	8.3	809	13.5	300	50	
	23	EC2-AKM23D-■■■■-20-05B	AKD-X00306	370	9.2	782	7.6	809	10.0	300	50	
	24	EC2-AKM23D-■■■■-50-05B	AKD-X00306	809	2.3	809	2.3	809	2.3	750	50	
	EC3	25	EC3-AKM23D-■■■■-15-16B	AKD-X00306	86	39.3	327	20.6	334	42.0	200	63
		26	EC3-AKM23D-■■■■-20-16B	AKD-X00306	119	28.6	448	14.0	459	30.0	300	63
		27	EC3-AKM23D-■■■■-50-16B	AKD-X00306	251	6.3	891	6.1	909	6.3	750	63
		28	EC3-AKM23D-■■■■-70-16B	AKD-X00306	349	4.5	1240	4.4	1260	4.5	1000	63
		29	EC3-AKM23D-■■■■-10-10B *	AKD-X00306	98	21.0	349	19.3	356	21.0	300	63
		30	EC3-AKM23D-■■■■-15-10B	AKD-X00306	141	21.0	523	12.9	534	21.0	300	63
		31	EC3-AKM23D-■■■■-20-10B	AKD-X00306	191	17.9	716	8.9	734	20.0	300	63
		32	EC3-AKM23D-■■■■-50-10B	AKD-X00306	404	3.8	1420	3.8	1450	3.8	1000	63
		33	EC3-AKM23D-■■■■-70-10B	AKD-X00306	561	2.8	1620	2.8	1620	2.8	1000	63
		34	EC3-AKM23D-■■■■-10-05B *	AKD-X00306	196	10.3	695	9.7	712	10.3	300	63
35		EC3-AKM23D-■■■■-15-05B	AKD-X00306	285	10.3	1040	6.4	1070	10.3	300	63	
36		EC3-AKM23D-■■■■-20-05B	AKD-X00306	381	8.9	1430	4.4	1470	10.0	300	63	
37		EC3-AKM23D-■■■■-50-05B	AKD-X00306	800	2.0	1620	2.0	1620	2.0	750	63	
38		EC3-AKM23D-■■■■-70-05B	AKD-X00306	1120	1.4	1620	1.4	1620	1.4	1000	63	
38		EC3-AKM42G-■■■■-10-16B *	AKD-X00606	149	45.0	601	24.4	628	45.0	200	63	
39		EC3-AKM42G-■■■■-15-16B	AKD-X00606	223	30.0	510	24.0	736	30.0	300	63	
40		EC3-AKM42G-■■■■-50-16B	AKD-X00606	690	6.3	1620	6.3	1620	6.3	750	63	
41		EC3-AKM42G-■■■■-70-16B	AKD-X00606	965	4.5	1620	4.5	1620	4.5	1000	63	
42		EC3-AKM42G-■■■■-10-10B *	AKD-X00606	238	28.4	961	15.3	1010	21.0	300	63	
43		EC3-AKM42G-■■■■-15-10B	AKD-X00606	357	18.9	823	14.5	1200	21.0	300	63	
44		EC3-AKM42G-■■■■-50-10B	AKD-X00606	1100	3.9	1620	3.9	1620	3.9	1000	63	
45		EC3-AKM42G-■■■■-70-10B	AKD-X00606	1530	2.8	1620	2.8	1620	2.8	1000	63	
46	EC3-AKM42G-■■■■-15-05B	AKD-X00606	710	10.3	1620	7.7	1620	10.3	300	63		

Note 1: Refer to page 66 for matching cables.  
 Note 2: For complete AKD and EC Series model nomenclature, refer to pages 67 and 73 respectively.  
 \* Inline type with 1-to-1 gear ratio (-10L) provide 10% additional thrust (not to exceed the max thrust).  
 \*\* Based on critical speed of screw specification.

### 240 Vac Performance Data

Sys #	Electric Cylinder - AKM Servomotor	AKD Servo Drive	Cont. Thrust @ Speed (lb @ in/sec)		Peak Thrust @ Speed (lb @ in/sec)		Max Thrust (lb)	Max System Speed (in/sec)	**Max Stroke for Max Speed (mm)	Cylinder Bore Size (EC)	
EC4	48	EC4-AKM42G-■■■■-10-25B *	AKD-X00606	108	52.5	395	36.1	402	52.5	300	80
	49	EC4-AKM42G-■■■■-15-25B	AKD-X00606	143	47.3	593	24.1	603	50.0	300	80
	50	EC4-AKM42G-■■■■-20-25B	AKD-X00606	190	35.4	791	18.1	804	36.0	450	80
	51	EC4-AKM42G-■■■■-50-25B	AKD-X00606	580	5.1	1940	5.1	1960	5.1	1500	80
	52	EC4-AKM42G-■■■■-100-25B	AKD-X00606	1130	2.6	2700	2.6	2700	2.6	1500	80
	53	EC4-AKM42G-■■■■-10-10B *	AKD-X00606	270	21.0	989	14.4	1005	15.3	450	80
	54	EC4-AKM42G-■■■■-15-10B	AKD-X00606	357	18.9	1480	9.6	1500	15.3	450	80
	55	EC4-AKM42G-■■■■-20-10B	AKD-X00606	476	14.2	1980	7.2	2010	14.5	450	80
	56	EC4-AKM42G-■■■■-50-10B	AKD-X00606	1440	2.1	2700	2.1	2700	2.1	1500	80
	57	EC4-AKM42G-■■■■-100-10B	AKD-X00606	2700	1.0	2700	1.0	2700	1.0	1500	80
	58	EC4-AKM52H-■■■■-10-25B *	AKD-X00606	256	36.3	458	30.7	668	36.3	300	80
	59	EC4-AKM52H-■■■■-15-25B	AKD-X00606	384	24.2	844	18.6	1200	24.2	600	80
	60	EC4-AKM52H-■■■■-20-25B	AKD-X00606	512	18.1	874	16.7	1160	18.1	750	80
	61	EC4-AKM52H-■■■■-50-25B	AKD-X00606	1360	5.1	2700	5.1	2700	5.1	1500	80
	62	EC4-AKM52H-■■■■-100-25B	AKD-X00606	2700	2.6	2700	2.6	2700	2.6	1500	80
	63	EC4-AKM52H-■■■■-10-10B *	AKD-X00606	640	14.5	1120	13.1	1670	14.5	450	80
	64	EC4-AKM52H-■■■■-15-10B	AKD-X00606	961	9.7	2090	8.0	2700	9.7	600	80
	65	EC4-AKM52H-■■■■-20-10B	AKD-X00606	1280	7.2	2190	6.7	2700	7.2	750	80
	66	EC4-AKM52H-■■■■-50-10B	AKD-X00606	2700	2.1	2700	2.1	2700	2.1	1500	80
	67	EC4-AKM52L-■■■■-10-25B *	AKD-X01206	240	52.5	422	52.5	700	52.5	300	80
	68	EC4-AKM52L-■■■■-15-25B	AKD-X01206	287	48.3	741	42.9	1090	48.3	300	80
	69	EC4-AKM52L-■■■■-20-25B	AKD-X01206	368	36.3	789	32.2	1040	36.3	450	80
	70	EC4-AKM52L-■■■■-50-25B	AKD-X01206	1370	5.1	2370	5.1	2370	5.1	1500	80
	71	EC4-AKM52L-■■■■-100-25B	AKD-X01206	2700	2.6	2700	2.6	2700	2.6	1500	80
	72	EC4-AKM52L-■■■■-10-10B *	AKD-X01206	650	15.3	1110	15.3	1500	15.3	300	80
73	EC4-AKM52L-■■■■-15-10B	AKD-X01206	860	15.3	1870	15.3	2700	15.3	300	80	
74	EC4-AKM52L-■■■■-20-10B	AKD-X01206	956	14.5	1970	13.0	2610	14.5	300	80	
75	EC4-AKM52L-■■■■-50-10B	AKD-X01206	2700	2.1	2700	2.1	2700	2.1	1500	80	
EC5	76	EC5-AKM42G-■■■■-10-32B *	AKD-X00606	88	52.5	309	46.3	314	52.5	450	100
	77	EC5-AKM42G-■■■■-15-32B	AKD-X00606	121	52.5	463	30.8	471	52.5	450	100
	78	EC5-AKM42G-■■■■-20-32B	AKD-X00606	149	45.4	618	23.1	628	45.4	450	100
	79	EC5-AKM42G-■■■■-50-32B	AKD-X00606	438	6.6	1530	6.6	1530	6.6	1500	100
	80	EC5-AKM42G-■■■■-100-32B	AKD-X00606	880	3.4	3000	3.4	3000	3.4	1500	100
	81	EC5-AKM42G-■■■■-10-10B *	AKD-X00606	270	15.3	989	14.4	1005	15.3	450	100
	82	EC5-AKM42G-■■■■-15-10B	AKD-X00606	400	15.3	1480	9.6	1510	15.3	450	100
	83	EC5-AKM42G-■■■■-20-10B	AKD-X00606	476	14.2	1980	7.2	2010	14.2	600	100
	84	EC5-AKM42G-■■■■-50-10B	AKD-X00606	438	6.6	1530	6.6	1530	6.6	1000	100
	85	EC5-AKM42G-■■■■-100-10B	AKD-X00606	880	3.4	3000	3.4	3000	3.4	1500	100
	86	EC5-AKM52H-■■■■-10-32B *	AKD-X00606	200	46.4	353	42.9	522	46.4	450	100
	87	EC5-AKM52H-■■■■-15-32B	AKD-X00606	300	30.9	935	2.3	935	30.9	750	100
	88	EC5-AKM52H-■■■■-20-32B	AKD-X00606	400	23.2	683	21.0	1010	23.2	750	100
	89	EC5-AKM52H-■■■■-50-32B	AKD-X00606	1080	6.6	3000	5.9	3045	6.6	1500	100
	90	EC5-AKM52H-■■■■-100-32B	AKD-X00606	2070	3.4	3630	3.4	3630	3.4	1500	100
	91	EC5-AKM52H-■■■■-10-10B *	AKD-X00606	641	14.5	1130	13.1	1670	14.5	450	100
	92	EC5-AKM52H-■■■■-15-10B	AKD-X00606	961	9.7	2080	8.0	3000	9.7	750	100
	93	EC5-AKM52H-■■■■-20-10B	AKD-X00606	1281	7.3	2180	6.7	3000	7.3	750	100
	94	EC5-AKM52H-■■■■-50-10B	AKD-X00606	3400	2.1	5620	2.1	5620	2.1	1500	100
	95	EC5-AKM52H-■■■■-100-10B	AKD-X00606	5620	1.0	5620	1.0	5620	1.0	1500	100
	96	EC5-AKM52L-■■■■-15-32B	AKD-X01206	261	52.5	580	52.5	853	52.5	450	100
	97	EC5-AKM52L-■■■■-20-32B	AKD-X01206	299	46.4	616	41.0	911	46.4	450	100
	98	EC5-AKM52L-■■■■-15-10B	AKD-X01206	860	15.3	1890	15.3	2730	15.3	450	100
	99	EC5-AKM52L-■■■■-20-10B	AKD-X01206	956	14.5	1970	12.8	2610	14.5	450	100

Note 1: Refer to page 66 for matching cables.

Note 2: For complete AKD and EC Series model nomenclature, refer to pages 67 and 73 respectively.

Ratings are based on the AKM servomotor and the matching AKD servo drive. Specifications are based on 240 Vac, 3 phase voltage supply.

\* Inline type with 1-to-1 gear ratio (-10L) provide 10% additional thrust (not to exceed the max thrust) \*\* Based on critical speed of screw specification.

# Rodless Actuators R-Series

AKD SERVO SYSTEMS

RODLESS ACTUATORS R-SERIES



The name rodless actuator comes from this technology's close relationship to electric cylinders, sharing many of the same components. Rather than having a rod, rodless actuators incorporate a carriage supported by linear bearings. Where electric cylinders are designed to extend in and out of the work area delivering force or thrust, rodless actuators are designed to be load carrying mechanisms (up to 300 lb) incorporating ballscrews, leadscrews, or belt drive transmissions with optional integrated gearheads.

Rodless actuators also share many of the fundamental design characteristics of precision positioning tables. Precision tables are designed to carry larger payloads and deliver superior repeatability and accuracy. Rodless actuators offer longer travels and higher speeds at a lower price. Screw driven rodless actuators are also thrust-producing devices that are best for axial force applications where the space is limited and a payload must also be supported or carried. As individual components, rodless actuators are not well suited for moment loading; however, they can be effectively combined into complete Cartesian systems for some multi-axis applications. For higher speed, lower thrust applications, rodless actuators can be repeatability-driven with a timing belt instead of a screw.

Kollmorgen has combined the broad product offering of the R-Series rodless actuators with the industry-leading AKM servomotors and AKD servo drives. The R-Series of rodless actuators offer a wide range of available thrusts in standard units with three basic frame sizes (R2A, R3, R4).

Rodless actuators offer longer travels (up to 108") and higher speeds (belt drives up to a maximum speed of 120 in/sec). Integrated geared options provide the ability to increase thrust capacity for lower speed applications leveraging the speed capacity of servo systems.

Multiple servomotor options are available for the product line, ranging from NEMA 23 size to NEMA 42 size servos. The combination with the AKM servomotor enables the use of various feedback devices including sine-encoder and the low-cost but high-performance Smart Feedback Device (SFD) when used with the AKD servo drive.

The AKM servomotor comes mounted on the rodless actuators as specified by the rodless actuator part number. This eliminates time to match the motor to the electric cylinder and eliminates potential mechanical incompatibility.

Sold & Serviced By:

 **ELECTROMATE**

Toll Free Phone (877) SERV098

Toll Free Fax (877) SERV099

[www.electromate.com](http://www.electromate.com)

[sales@electromate.com](mailto:sales@electromate.com)



**The operation of rodless actuators is similar to the electric cylinders described earlier.** However, instead of an extending rod, a rodless unit features a moving carriage supported by linear bearings within an extruded aluminum chassis. This gives the rodless actuator the ability to guide and support a load, as well as position it.

Kollmorgen rodless actuators are designed for outstanding overall performance, value, flexibility and reliability in industrial applications.

#### Rodless Actuators Are Preferred When:

- A low cost system is needed to both position and guide a load
- It is desired to eliminate external guides and ways
- The shortest overall work envelope (extended length equals retracted length) is required
- Multiple units will be combined into Cartesian systems
- There is a need for a compact cross-sectional linear positioning system

#### Typical Construction

(R4 belt-driven cutaway shown)

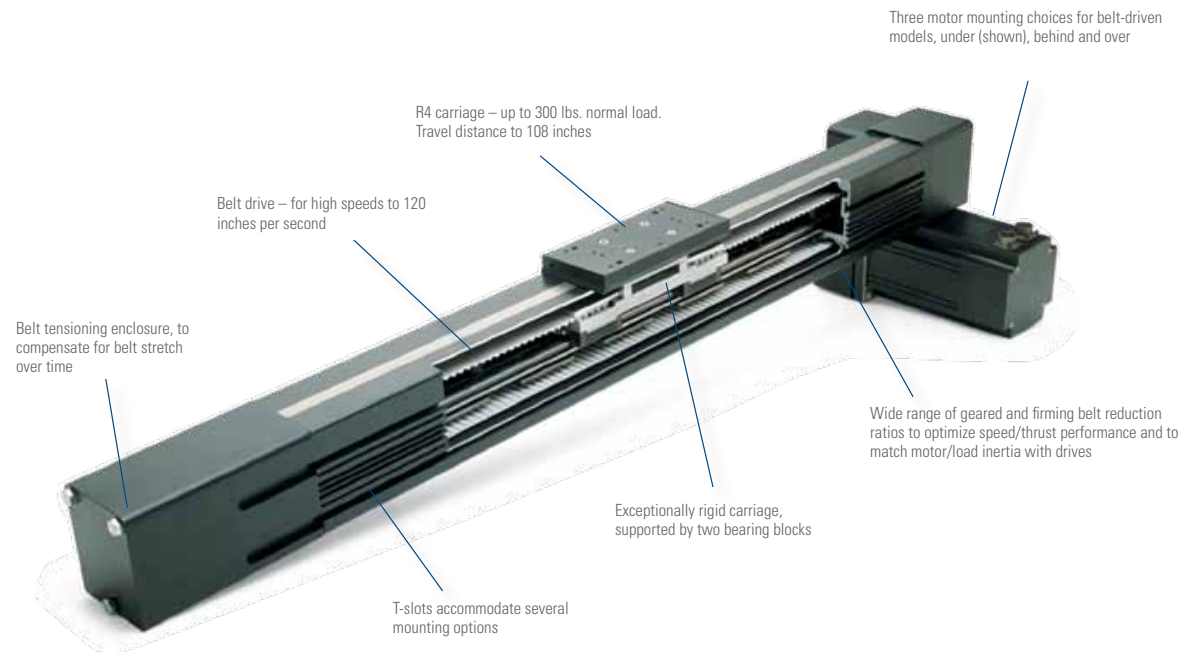

Sold & Serviced By:

**ELECTROMATE**

Toll Free Phone (877) SERV098

Toll Free Fax (877) SERV099

[www.electromate.com](http://www.electromate.com)

[sales@electromate.com](mailto:sales@electromate.com)

# Rodless Actuators R-Series

## R3 Screw Drive

R3 screw drive with AKM42, parallel below motor orientation and flange mounting shown.

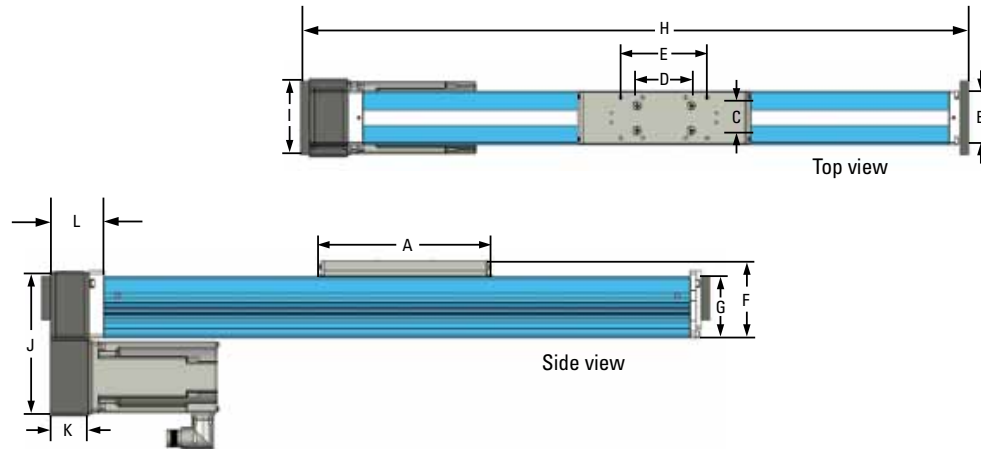

## R3 Belt Drive

R3 belt drive with AKM42, behind left motor orientation and angle bracket feet shown.

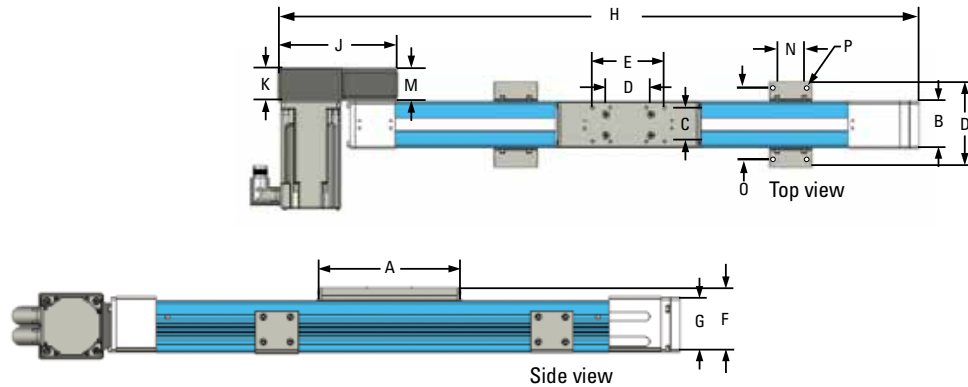

### Carriage Mounting Features

	Metric Version (mm)	English Version (inch)
RA2	8 x M5 x 0.8 x 8.0 deep	8 x 10-32 UNF x 0.31 deep
R3	8 x M5 x 0.8 x 9.6 deep	8 x 10-32 UNF x 0.38 deep
R4	4 x M6 x 1 x 12 deep	4 x 1/4-20 x 0.50 deep

### Dimension Data

	A	B	C	D	E
	mm (in)	mm (in)	mm (in)	mm (in)	mm (in)
RA2	210 (8.25)	50.8 (2.00)	31.8 (1.25)	50.8 (2.00)	101.6 (4.00)
R3	197 (7.76)	63.5 (2.50)	47.6 (1.88)	50.8 (2.00)	101.6 (4.00)
R4	197 (7.76)	92.2 (3.63)	63.5 (2.50)	NA	127.0 (5.00)

	F	G	H (Screw)	H (Belt)
	mm (in)	mm (in)	mm (in)	mm (in)
RA2	71.9 (2.83)	50.8 (2.00)	"S" + 345.3 (13.59)	"S" + 378.3 (14.89)
R3	88.8 (3.50)	71.5 (2.82)	"S" + 326.4 (12.85)	"S" + 522.0 (20.55)
R4	71.9 (2.83)	108.0 (4.25)	"S" + 411.8 (16.21)	"S" + 578.6 (22.78)

S = stroke

	I	J	K	L
	mm (in)	mm (in)	mm (in)	mm (in)
RA2	72.1 (2.84)	123.2 (4.85)	43.0 (1.69)	90.7 (3.57)
R3	91.4 (3.60)	168.9 (6.65)	45.5 (1.79)	88.1 (3.47)
R4	127.0 (5.00)	220.7 (8.69)	71.9 (2.83)	147.8 (5.82)

	M	N	O	P
	mm (in)	mm (in)	mm (in)	mm (in)
RA2	50.1 (1.97)	NA	88.8 (3.50)	8.7 (0.34) thru
R3	45.5 (1.79)	47.6 (1.88)	101.6 (4.00)	5.5 (0.22) thru
R4	71.9 (2.83)	63.5 (2.50)	127.0 (5.00)	7.0 (0.28) thru

Sold & Serviced By:

 **ELECTROMATE**

Toll Free Phone (877) SERV098

Toll Free Fax (877) SERV099

[www.electromate.com](http://www.electromate.com)

[sales@electromate.com](mailto:sales@electromate.com)

# Rodless Actuators R-Series

## General Specifications

Series	R2A			R3			R4	
Std max stroke length (in)	72			108			108	
Cross section (in)	2 x 2			2.5 x 2.8			3.6 x 4.25	
Guide type	Roller Guides			Profile Rail			Profile Rail	
Drive type	Ballscrew	Lead Screw	Belt	Ballscrew	Lead Screw	Belt	Ballscrew	Belt
Screw leads (in/rev)	0.5, 0.2	0.2, 0.125	n/a	0.5, 0.2	0.2, 0.125	n/a	1, 0.25	n/a
Nominal screw diameter (in)	0.625	0.625	n/a	0.625	0.625	n/a	1	n/a
Brushless servomotor	AKM23, NEMA 23			AKM23, NEMA 23, AKM42, NEMA 34			n/a	
Max thrust (lb)	100		72	300		200	700	300
Max velocity (in/sec)	30		80	30		120	40	120
Max carriage load								
Normal (lb)	50			100			300	
Roll moment (lb-in)	50			300			600	
Pitch moment (lb-in)	100			500			1000	
Repeatability (in)	+/-0.001		+/-0.010	+/-0.001		+/-0.010	+/-0.001	+/-0.010
Max duty cycle (speed, load dependent)	100%	60%	100%	100%	60%	100%	100%	100%
Limit sensors	Optional							
Std operating temperature range	-20 deg F to 140 deg F (-28 deg C to 60 deg C)							
Moisture/contamination	IP 44 rated: Splash-proof, protected against ingress of solid particles greater than 0.040 [1 mm] diameter.*							

## 240 Vac Performance Data

Sys #	Rodless Actuator-Servomotor	AKD Servo Drive	Cont. Thrust @ Speed (lb @ in/sec)		Peak Thrust @ Speed (lb @ in/sec)		Max Thrust (lb)	Max System Speed (in/sec)	Max Stroke for Max Speed (in)	
R2A	1	R2A-AKM23D-10-2B*	AKD-X00306	70	30	100	30	100	30	18
	2	R2A-AKM23D-15-2B	AKD-X00306	100	20	100	20	100	20	24
	3	R2A-AKM23D-20-2B	AKD-X00306	100	15	100	15	100	15	30
	4	R2A-AKM23D-10-5B	AKD-X00306	100	12	100	12	100	12	18
	5	R2A-AKM23D-15-5B	AKD-X00306	100	8.0	100	8.0	100	8.0	24
	6	R2A-AKM23D-20-5B	AKD-X00306	100	6.0	100	6.0	100	6.0	30
	7	R2A-AKM23D-10-5A*	AKD-X00306	79	12	100	12	100	12	12
	8	R2A-AKM23D-15-5A	AKD-X00306	100	8.0	100	8.0	100	8.0	18
	9	R2A-AKM23D-20-5A	AKD-X00306	100	6.0	100	6.0	100	6.0	24
	10	R2A-AKM23D-10-T*	AKD-X00306	7.0	80	40	80	40	80	72
	11	R2A-AKM23D-15-T	AKD-X00306	13	80	64	80	64	80	72
	12	R2A-AKM23D-20-T	AKD-X00306	19	80	78	80	87	80	72
R3	13	R3-AKM23D-10-2B*	AKD-X00306	71	30	269	25	275	30	18
	14	R3-AKM23D-15-2B	AKD-X00306	110	20	300	20	300	20	24
	15	R3-AKM23D-20-2B	AKD-X00306	148	15	300	15	300	15	30
	16	R3-AKM23D-50-2B	AKD-X00306	300	6.0	300	6.0	300	6.0	48
	17	R3-AKM23D-10-5B*	AKD-X00306	186	12	300	12	300	12.0	18
	18	R3-AKM23D-15-5B	AKD-X00306	283	8.0	300	8.0	300	8.0	24
	19	R3-AKM23D-20-5B	AKD-X00306	300	6.0	300	6.0	300	6.0	30
	20	R3-AKM23D-50-5B	AKD-X00306	300	2.4	300	2.4	300	2.4	48
	21	R3-AKM23D-10-5A*	AKD-X00306	80	12	250	12	300	12	12
	22	R3-AKM23D-15-5A	AKD-X00306	122	8.0	300	8.0	300	8.0	18
	23	R3-AKM23D-20-5A	AKD-X00306	165	6.0	300	6.0	300	6.0	24
	24	R3-AKM23D-50-5A	AKD-X00306	300	2.4	300	2.4	300	2.4	42
	25	R3-AKM23D-10-8A*	AKD-X00306	131	7.5	300	7.5	300	7.5	18
	26	R3-AKM23D-15-8A	AKD-X00306	199	5.0	300	5.0	300	5.0	30
	27	R3-AKM23D-20-8A*	AKD-X00306	267	3.8	300	3.8	300	3.7	30
	28	R3-AKM23D-50-8A	AKD-X00306	300	1.5	300	1.5	300	1.5	48
	29	R3-AKM23D-10-T*	AKD-X00306	1.2	110	18	110	18	110	108

Note 1: Refer to page 66 for matching cables. Note 2: For complete AKD and R-Series model nomenclature, refer to pages 67 and 75 respectively.

\* Inline tune with 1-to-1 gear ratio (-10:1) provide 10% additional thrust (not to exceed the max thrust)

Sold & Serviced By:



Toll Free Phone (877) SERV098

Toll Free Fax (877) SERV099

www.electromate.com

sales@electromate.com

## 240 Vac Performance Data

Sys #	Rodless Actuators-Servomotor	AKD Servo Drive	Cont. Thrust @ Speed (lb @ in/sec)		Peak Thrust @ Speed (lb @ in/sec)		Max Thrust (lb)	Max System Speed (in/sec)	Max Stroke for Max Speed (in)	
R2	30	R3-AKM23D-15-T	AKD-X00306	4.4	110	29	110	29	110	108
	31	R3-AKM23D-20-T	AKD-X00306	8.0	110	40	110	41	110	108
	32	R3-AKM23D-50-T	AKD-X00306	20	72	90	72	92	72	108
	33	R3-AKM23D-70-T	AKD-X00306	30	51	128	51	131	51	108
	34	R3-AKM42G-10-2B	AKD-X00606	200	30	300	30	300	30	18
	35	R3-AKM42G-15-2B	AKD-X00606	300	20	300	20	300	20	24
	36	R3-AKM42G-20-2B	AKD-X00606	300	15	300	15	300	15	30
	37	R3-AKM42G-50-2B	AKD-X00606	300	6.0	300	6.0	300	6.0	48
	38	R3-AKM42G-10-5B	AKD-X00606	300	12	300	12	300	12	18
	39	R3-AKM42G-15-5B	AKD-X00606	300	8.0	300	8.0	300	8.0	24
	40	R3-AKM42G-20-5B	AKD-X00606	300	6.0	300	6.0	300	6.0	30
	41	R3-AKM42G-50-5B	AKD-X00606	300	2.4	300	2.4	300	2.4	48
	42	R3-AKM42G-10-5A	AKD-X00606	221	12	300	12	300	12	12
	43	R3-AKM42G-15-5A	AKD-X00606	300	8.0	300	8.0	300	8.0	18
	44	R3-AKM42G-20-5A	AKD-X00606	300	6.0	300	6.0	300	6.0	24
	45	R3-AKM42G-50-5A	AKD-X00606	300	2.4	300	2.4	300	2.4	42
	46	R3-AKM42G-10-8A	AKD-X00606	300	7.5	300	7.5	300	7.5	18
	47	R3-AKM42G-15-8A	AKD-X00606	300	5.0	300	5.0	300	5.0	24
	48	R3-AKM42G-20-8A	AKD-X00606	300	3.8	300	3.8	300	3.8	30
	49	R3-AKM42G-50-8A	AKD-X00606	300	1.5	300	1.5	300	1.5	60
	50	R3-AKM42G-10-T	AKD-X00606	15	110	59	110	60	110	108
	51	R3-AKM42G-15-T	AKD-X00606	25	110	92	110	93	110	108
	52	R3-AKM42G-20-T	AKD-X00606	32	110	124	110	126	110	108
	53	R3-AKM42G-50-T	AKD-X00606	66	72	200	72	200	72	108
54	R3-AKM42G-70-T	AKD-X00606	94	51	200	51	200	51	108	
R4	55	R4-AKM42G-10-1B	AKD-X00606	103	40	384	37	390	40	36
	56	R4-AKM42G-15-1B	AKD-X00606	160	27	578	25	588	27	48
	57	R4-AKM42G-20-1B	AKD-X00606	210	20	700	20	700	20	60
	58	R4-AKM42G-50-1B	AKD-X00606	460	7.8	700	7.8	700	7.8	96
	59	R4-AKM42G-100-1B	AKD-X00606	700	4.0	700	4.0	700	4.0	108
	60	R4-AKM42G-10-4B	AKD-X00606	440	10.0	700	10.0	700	10	36
	61	R4-AKM42G-15-4B	AKD-X00606	630	6.7	700	6.7	700	6.7	48
	62	R4-AKM42G-20-4B	AKD-X00606	700	6.7	700	6.7	700	6.7	48
	63	R4-AKM42G-50-4B	AKD-X00606	700	6.7	700	6.7	700	6.7	48
	64	R4-AKM42G-10-T	AKD-X00606	11	110	47	110	47	110	108
	65	R4-AKM42G-15-T	AKD-X00606	18	110	73	110	74	110	108
	66	R4-AKM42G-20-T	AKD-X00606	25	110	98	110	100	110	108
	67	R4-AKM42G-30-T	AKD-X00606	38	100	150	92	153	100	108
	68	R4-AKM42G-50-T	AKD-X00606	56	59	215	54	219	59	108
	69	R4-AKM42G-100-T	AKD-X00606	118	30	300	30	300	30	108
	70	R4-AKM52H-10-1B	AKD-X00606	246	37	700	37	700	37	36
	71	R4-AKM52H-15-1B	AKD-X00606	372	25	700	25	700	25	48
	72	R4-AKM52H-20-1B	AKD-X00606	498	18	700	18	700	18	60
	73	R4-AKM52H-50-1B	AKD-X00606	700	7.8	700	7.8	700	7.8	96
	74	R4-AKM52H-10-4B	AKD-X00606	700	9.2	700	9.2	700	9.2	36
	75	R4-AKM52H-15-4B	AKD-X00606	700	6.7	700	6.7	700	6.7	48
	76	R4-AKM52H-20-4B	AKD-X00606	700	4.9	700	4.9	700	4.9	60
	77	R4-AKM52H-50-4B	AKD-X00606	700	1.9	700	1.9	700	1.9	96
	78	R4-AKM52H-10-T	AKD-X00606	30	110	97	110	99	110	108
	79	R4-AKM52H-15-T	AKD-X00606	51	110	149	110	152	110	108
	80	R4-AKM52H-20-T	AKD-X00606	65	110	201	90	204	110	108
	81	R4-AKM52H-30-T	AKD-X00606	95	92	300	60	300	95	108
	82	R4-AKM52H-50-T	AKD-X00606	137	54	300	44	300	54	108
	83	R4-AKM52H-100-T	AKD-X00606	275	27	300	27	300	27	108

Note 1: Refer to page 66 for matching cables. Note 2: For complete AKD and R-Series model nomenclature, refer to pages 67 and 75 respectively.

# Micron™ TRUE Planetary™ Gearhead

Helical gears are known for their quiet and smooth operation along with their ability to transmit higher loads than spur gears. Both of these features of helical gearing result from the improved contact ratio (effective teeth in mesh) over spur gears.

A high torque, whisper quiet helical gearhead has been designed by combining the positive attributes of gear crowning and helical gearing with the planetary construction to create the smoothest operating gearhead on the market.

- Broadest product range of gearheads in the industry
- Innovative gear technology offers size and performance advantages
- RediMount™ system provides error-free and reliable installations

## Helical Crowned TRUE Planetary™ Gearing

### Features

- High torque capacity
- Low backlash
- Smooth operation
- Greater load sharing
- Whisper quiet

### Spur vs. Helical Gearing

Typical contact ratio is 1.5 for spur gearing. Contact ratio for equivalent helical gear is 3.3 – more than double the contact ratio.

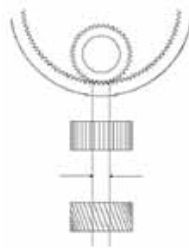

### Crowned vs. Non-Crowned

Crowning optimizes the gear mesh alignment within a gear train to increase the torque capacity and reduce noise. It also enhances load distribution on the tooth flank to reduce high stress regions.

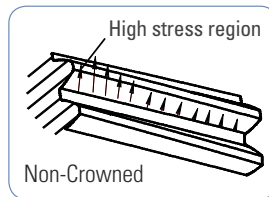

Non-Crowned

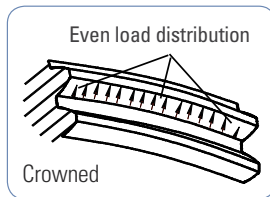

Crowned

## PowerTRUE™ Right Angle Gearheads

- Lower backlash from single axis mesh adjustment
- A compact design using face gear technology
- Whisper quiet operation due to high contact ratio
- Mesh ratios from 1:1 to 5:1
- Extremely efficient (98%)

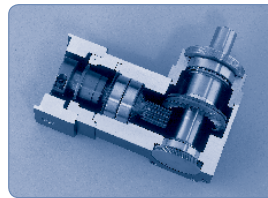

PowerTRUE™ gear technology

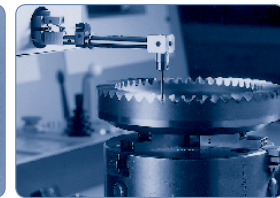

Computerized mapping of gear tooth profile

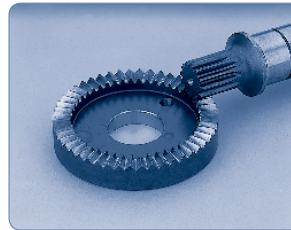

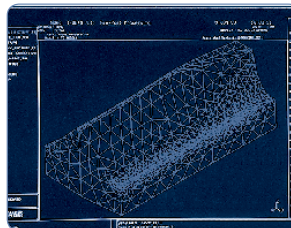

All Micron™ right angle gearheads use the PowerTRUE technology which increases the mesh ratio to 5:1 compared to a maximum of 3:1 typical in bevel gears.



Multiple teeth in the face gear simultaneously mesh with a standard involute pinion. The continuous tooth engagement yields a high contact ratio between the gear and the pinion, increasing torque and efficiency.

NEMA TRUE™	True planetary gearhead, flange mount design with anodized aluminum housing employing RediMount™ system.								
	Inline	Frame Size		Max T Peak (lb-in)		All Sizes	Gear Ratios Available	Efficiency	Backlash (arc-min)
		English	Metric	1 Stage	2 Stage				
	Size 17	NEMA 17	42 mm	170	170	1 Stage	3, 4, 5, 7, 10	93%	13 (8)*
	Size 23 / 60	NEMA 23	60 mm	250	275				
	Size 34 / 90	NEMA 34	90 mm	700	850	2 Stage	15, 20, 25, 30, 40, 50, 70, 100	88%	15 (9)*
	Size 42 / 115	NEMA 42	115 mm	1000	1600				

NEMA TRUE™	True planetary gearhead, flange mount design with anodized aluminum housing employing RediMount™ system.									
	Right Angle	Frame Size		Max T Peak (lb-in)			All Sizes	Gear Ratios Available	Efficiency	Backlash (arc-min)
		English	Metric	1 Stage	2 Stage	3 Stage				
	Size 23 / 60	NEMA 23	60 mm	360	366	366	1 Stage	1, 2, 3, 4, 5P	98%	13
	Size 34 / 90	NEMA 34	90 mm	1110	1110	1110	2 Stage	5T, 6, 9, 10, 12, 15, 20, 25, 30, 40, 50	93%	15
	Size 42 / 115	NEMA 42	115 mm	2250	2250	2250	3 Stage	60, 75, 90, 100, 120, 125, 150, 200, 250, 300, 400, 500	88%	15

XTRUE™	The XTRUE Series is a new precision gearhead employing RediMount™ system that compliments our TRUE planetary gearhead line – already the largest selection of planetary gearheads in the world.								
	Inline	Frame Size Metric	Max T Peak (lb-in)		All Sizes	Gear Ratios Available	Efficiency	Backlash (arc-min)	
			1 Stage	2 Stage					
	XT040	40 mm	162	299	1 Stage	3, 4, 5, 7, 10	93%	13	
	XT060	60 mm	483	483					
	XT080	80 mm	1460	1550					
	XT120	120 mm	2640	2640	2 Stage	15, 20, 25, 30, 40, 50, 70, 100	88%	15	
	XT160	160 mm	7750	7750					

EverTRUE™	EverTRUE, employing RediMount™ system, is specifically designed for 24/7 continuous running applications providing 3 times (30,000 hours) service life.								
	Inline	Frame Size Metric	Max T Peak (lb-in)		All Sizes	Gear Ratios Available	Efficiency	Backlash (arc-min)	
			1 Stage	2 Stage					
	ET010	101 mm	4090	4790	1 Stage	4, 5, 7, 10	95%	4	
	ET014	141 mm	9430	11,250					
	ET018	182 mm	21,600	26,280	2 Stage	16, 20, 25, 28, 35, 40, 50, 70, 100	90%	5	

\* High Precision, low backlash versions available, low backlash value in parenthesis (Not available in size 17).

Note 1: Torque capacity is maximum of frame size stage design, not all ratios have the same rated torque capacity.

Note 2: Torque capacity is the maximum allowable momentary torque for emergency stopping or heavy shock loading.

Note 3: Ratio 5P is designed using the compact PowerTrue face gearing technology.

Note 4: Ratio 5T is designed using a True planetary gear stage for increased torque capacity.

Note 5: For complete gearhead model nomenclature, refer to page 76.



Sold & Serviced By:

 **ELECTROMATE**

Toll Free Phone (877) SERV098

Toll Free Fax (877) SERV099

www.electromate.com

sales@electromate.com

# Micron™ TRUE Planetary™ Gearhead

AKD SERVO SYSTEMS

TRUE PLANETARY GEARHEAD

	DuraTRUE™ True planetary gearhead, flange mount design with anodized aluminum housing employing RediMount™ system.							
	Inline	Frame Size Metric	Max T Peak (lb-in)		All Sizes	Gear Ratios Available	Efficiency	Backlash (arc-min)
			1 Stage	2 Stage				
	DT60	60 mm	460	460	1 Stage	3, 4, 5, 7, 10	93%	9
	DT90	90 mm	1480	1480				
	DT115	115 mm	2510	2510	2 Stage	15, 20, 25, 30, 40, 50, 70, 100	88%	8
	DT142	142 mm	7380	7380				

	DuraTRUE™ True planetary right angle gearhead, flange mount design with anodized aluminum housing employing RediMount™ system.							
	Right Angle	Frame Size Metric	Max T Peak (lb-in)		All Sizes	Gear Ratios Available	Efficiency	Backlash (arc-min)
			1 Stage	2 Stage				
	DT60	60 mm	460	460	1 Stage	5, 6, 9, 10, 12, 15, 20, 25, 30, 40, 50	93%	9
	DT90	90 mm	1480	1480				
	DT115	115 mm	2510	2510	2 Stage	60, 75, 90, 100, 120, 125, 150, 200, 250, 300, 400, 500	88%	8
	DT142	142 mm	7380	7380				

	Slimline right angle gearhead, flange mount design with anodized aluminum housing employing RediMount™ system. Face gear technology for compact right angle construction. Dual shaft output version also available.								
	Right Angle	Frame Size Metric	Max T Peak (lb-in)			All Sizes	Gear Ratios Available	Efficiency	Backlash (arc-min)
			1 Stage	2 Stage	3 Stage				
	DT60S	60 mm	460	400	400	1 Stage	1, 2, 3, 4, 5P	98%	8
	DT90S	90 mm	1240	1240	1240	2 Stage	5T, 6, 9, 10, 12, 15, 20, 25, 30, 40, 50	93%	9
	DT115S	115 mm	2260	2500	2500	3 Stage	60, 75, 90, 100, 120, 125, 150, 200, 250, 300, 400, 500	88%	9
	DT142S	142 mm	5500	6920	7450				

	Hollow Shaft Hollow shaft right angle gearhead, flange mount design with anodized aluminum housing employing RediMount™ system. Large diameter/ bolt circle for direct mechanical interface. Face gear technology for compact right angle construction.								
	Right Angle	Frame Size Metric	Max T Peak (lb-in)			All Sizes	Gear Ratios Available	Efficiency	Backlash (arc-min)
			1 Stage	2 Stage	3 Stage				
	DT90H	90 mm	1240	1240	1240	1 Stage	1, 2, 3, 4, 5P	98%	8
	DT115H	115 mm	2500	2500	2500	2 Stage	5T, 6, 9, 10, 12, 15, 20, 25, 30, 40, 50	93%	9
	DT142H	142 mm	7660	7660	7660	3 Stage	60, 75, 90, 100, 120, 125, 150, 200, 250, 300, 400, 500	88%	9

Note 1: Torque Capacity is maximum of frame size stage design, not all ratios have the same rated torque capacity.  
 Note 2: Torque Capacity is the maximum allowable momentary torque for emergency stopping or heavy shock loading.  
 Note 3: Ratio 5P is designed using the compact PowerTrue face gearing technology.  
 Note 4: Ratio 5T is designed using a True planetary gear stage for increased torque capacity.  
 Note 5: For complete gearhead model nomenclature, refer to page 76.



Sold & Serviced By:  



Toll Free Phone (877) SERV098  
 Toll Free Fax (877) SERV099  
[www.electromate.com](http://www.electromate.com)  
[sales@electromate.com](mailto:sales@electromate.com)



ValueTRUE™		Helical True planetary gearhead, flange mount design with stainless steel housing employing RediMount™ system.						
Image	Inline	Frame Size Metric	Max T Peak (lb-in)		All Sizes	Gear Ratios Available	Efficiency	Backlash (arc-min)
			1 Stage	2 Stage				
	VT006	61 mm	800	910	1 Stage	4, 5, 7, 10	95%	4
	VT075	75 mm	1420	1630				
	VT090	90 mm	1420	1630				
	VT010	101 mm	4090	4790				
	VT115	115 mm	4090	4790	2 Stage	16, 20, 25, 28, 35, 40, 50, 70, 100	93%	5
	VT014	141 mm	9430	11,250				
	VT018	182 mm	21,600	26,280				
	VT022	220 mm	36,980	44,000				

ValueTRUE™		Helical True planetary gearhead, flange mount design with stainless steel housing employing RediMount™ system.						
Image	Right Angle	Frame Size Metric	Max T Peak (lb-in)		All Sizes*	Gear Ratios Available	Efficiency	Backlash (arc-min)
			2 Stage					
	VTR006	61 mm	870		2 Stage	4, 5, 8, 10, 12, 14, 15, 16, 20, 25, 28, 30, 35, 40, 50	93%	5
	VTR075	75 mm	1570					
	VTR090	90 mm	1570					
	VTR010	101 mm	4580					
	VTR115	115 mm	4580					
	VTR014	141 mm	10,670					
	VTR018	182 mm	24,780					

\* 4 and 5:1 ratios not available with VTR006-VTR090.

UltraTRUE™		Helical True planetary inline gearhead, flange mount design with anodized aluminum housing employing RediMount™ system. Stainless steel housing, gear-path hobbled into stainless steel housing.						
Image	Inline	Frame Size Metric	Max T Peak (lb-in)		All Sizes	Gear Ratios Available	Efficiency	Backlash (arc-min)
			1 Stage	2 Stage				
	UTO06	61 mm	890	1010	1 Stage	4, 5, 7, 10	95%	4
	UTO75	75 mm	1580	1810				
	UTO90	90 mm	1580	1810				
	UTO10	101 mm	4540	5330				
	UT115	115 mm	4540	5330	2 Stage	16, 20, 25, 28, 35, 40, 50, 70, 100	90%	5
	UTO14	141 mm	10,480	12,500				
	UTO18	182 mm	24,101	29,200				
	UTO22	220 mm	41,090	48,890				

UltraTRUE™		Helical True planetary right angle gearhead, flange mount design with anodized aluminum housing employing RediMount™ system. Stainless steel housing, gear-path hobbled into stainless steel housing.						
Image	Right Angle	Frame Size Metric	Max T Peak (lb-in)		All Sizes	Gear Ratios Available	Efficiency	Backlash (arc-min)
			1 Stage	2 Stage				
	UTR006	61 mm	450	970	1 Stage	1, 2, 3, 4, 5	98%	4
	UTR075	75 mm	1410	1740				
	UTR090	90 mm	1410	1740				
	UTR010	101 mm	2850	5080				
	UTR115	115 mm	2850	5080	2 Stage	8, 10, 12, 14, 15, 16, 20, 25, 28, 30, 35, 40, 50	93%	5
	UTR014	141 mm	6270	11,860				
	UTR018	182 mm	16,910	27,530				

Note 1: Torque capacity is maximum of frame size stage design, not all ratios have the same rated torque capacity.  
 Note 2: Torque capacity is the maximum allowable momentary torque for emergency stopping or heavy shock loading.  
 Note 3: Ratio 5P is designed using the compact PowerTrue face gearing technology.  
 Note 4: Ratio 5T is designed using a True planetary gear stage for increased torque capacity.  
 Note 5: For complete gearhead model nomenclature, refer to page 76.



# Stepper Products

**Our stepper motors, drives and controllers, which accommodate a wide range of power requirements, provide a high-performance, yet very cost-effective solution when you need precise motion control.** In addition, our stepper motors are the highest torque-density motors in the industry, simple to control and don't require complicated, expensive feedback devices. They're available in a wide range of lengths, windings and shafts.

We also offer hybrid stepper motors that deliver more power in a smaller package. These rugged NEMA 34 and 42 (90 and 110 mm) frame motors provide among the highest torques per frame size in the industry.

Due to their ease of use, simplified control needs and freedom from expensive feedback requirements, our step motors are excellent alternatives to pneumatic, hydraulic and servomotor systems.

Sold & Serviced By:

 **ELECTROMATE**

Toll Free Phone (877) SERV098

Toll Free Fax (877) SERV099

[www.electromate.com](http://www.electromate.com)

[sales@electromate.com](mailto:sales@electromate.com)

# P7000 Stepper Drive-Controller

P7000 stepper drives offer a unique level of system functionality, smoothness, high-speed performance and innovation unmatched in the industry.

The compact P7000 is designed to power Kollmorgen step motors ranging from NEMA size 17 up to NEMA size 34. Two power configurations are available for operation directly from AC power, or from a DC power supply.

There are two levels of control offered. The basic drive accepts step and direction inputs. P7000 drives are also available with an integrated position controller (-PN option). The drives are configured by either on-board dip switches, or with the P7000 tools software.



## Advanced P7000 Features Make it the Best Choice to Meet Your Application Requirements

### Multisteping™

Also known as auto-smoothing. The P7000 drive accepts full step pulse commands from the indexer and inserts fine micro-steps to smooth coarse low speed motion. This allows you to significantly upgrade machine performance without having to redesign machine control architecture.

### Auto-Tuning

Advanced current auto-tuning techniques provide outstanding low-speed smoothness. The P7000 senses the motor's characteristics and automatically fine tunes itself to meet your high-performance needs. This reduces installation and set-up time.

### Mid-Band Anti-Resonance Control

Reduces negative effects of mechanical resonance, allowing you to get more out of a smaller motor and virtually eliminating nuisance stalls and machine downtime.

### Idle Current Reduction

If you do not require the motor's full torque to hold a load at rest, you can select the right amount of current (torque) to reduce motor heating and power consumption. This increases the life of the system.

### Dynamic Smoothing

Quasi-S-curve algorithm reduces jerk, especially upon acceleration. Increases mechanical life of the machine and reduces energy consumption.

### Intelligent Indexing Option (-PN)

Wizard-like P7000 helps you to develop and link motion tasks such as homing and conditional and unconditional indexing. You can be up-and-running quickly.

### Modbus RTU Compatible

The intelligent indexing option (-PN) supports Modbus RTU to control motion with an external interface device. External interfaces make controlling motion simple for machine operators.

### P7000 Tools

The position node option allows you to configure up to 63 absolute or relative moves. You can specify the moves' distance, acceleration, velocity, and deceleration rates, or simply specify the distance and total time for the move – P7000 will perform the calculations automatically.

Specifications	Units	P70530	P70360
Input voltage range	Volts	20 - 75 Vdc	120 or 240 Vac
Continuous current	Amps rms	5	2.5
Microstep peak current	Amps peak	7.1	3.5

Note: For complete P7000 Series model nomenclature, refer to page 77.



Sold & Serviced By:

**ELECTROMATE**

Toll Free Phone (877) SERV098

Toll Free Fax (877) SERV099

[www.electromate.com](http://www.electromate.com)

[sales@electromate.com](mailto:sales@electromate.com)

# Hybrid Step Motor

Our step motors have higher performance and support larger shaft loads than any other step motors. Custom motors are available to meet specific application needs including: modified shafts, connectors, lead-screws, and shaft-mounted components.

## CT Series

CT Series motors include the most popular sizes, options and value suitable for most commercial and industrial applications. Enhanced motors provide the maximum performance available. This patented technology boosts torque an additional 25% to 40% across the entire speed range, and allows machines to be designed that are smaller and move faster.

### CT Series Benefits

- Smaller drives result in a lower system cost
- More torque allows for smaller, faster machines
- Higher efficiency enables lower operating costs

Size 17 CT Series		2 Phase, 1.8° Step Motors. Frame size: 1.7 inch, 43 mm (CTP High Torque Performance Series)					
Series	Construction		Holding Torque (Motor Mounted)		Length		<ul style="list-style-type: none"> <li>• Inch or metric mounting</li> <li>• Rear shaft option</li> </ul>
	Style	Stacks	Bipolar		in	mm	
			oz-in	Nm			
CTP10	Un-Enhanced	Short	43	0.30	1.37	34.7	
CTP11		1	62	0.44	1.61	40.9	
CTP12		2	80	0.56	1.92	48.8	



Size 23 CT Series		2 Phase, 1.8° Step Motors. Frame size: 2.2 inch, 57 mm (CTM Enhanced-Max Torque and Efficiency, CTP High Torque Performance Series)					
Series	Construction		Holding Torque (Motor Mounted)		Length		<ul style="list-style-type: none"> <li>• Captured heavy duty bearings</li> <li>• High voltage insulation system</li> <li>• Rear shaft option</li> </ul>
	Style	Stacks	Bipolar		in	mm	
			oz-in	Nm			
CTM21	Enhanced	1	260	1.84	2.13	54.1	
CTM22		2	470	3.32	3.32	84.3	
CTP20	Un-Enhanced	Short	100	0.71	1.62	41.2	
CTP21		1	200	1.41	2.13	54.1	
CTP22		2	360	2.54	3.32	84.3	



Size 34 CT Series		2 Phase, 1.8° Step Motors. Frame size: 3.4 inch, 87 mm (CTM Enhanced-Max Torque & Efficiency, CTP High Torque Performance Series)					
Series	Construction		Holding Torque (Motor Mounted)		Length		<ul style="list-style-type: none"> <li>• Captured heavy duty bearings</li> <li>• High voltage insulation system</li> <li>• Standard keyway front shaft</li> <li>• Rear shaft option</li> </ul>
	Style	Stacks	Bipolar		in	mm	
			oz-in	Nm			
CTM31	Enhanced	1	690	4.9	2.54	64.5	
CTM32		2	1350	9.5	3.80	96.5	
CTM33		3	1930	13.6	5.06	129	
CTP31	Un-Enhanced	1	565	4.0	2.54	64.5	
CTP32		2	1100	7.8	3.80	96.5	
CTP33		3	1580	11.2	5.06	129	



Note: For complete CT Series model nomenclature, refer to page 78.



### N/K Series

The N/K Series are larger step motors with the power, rugged construction, and options that make these motors ideal for heavy industrial applications. Options include: IP56, terminal boxes and MS connectors. Enhanced versions provide the maximum performance torque available. This patented technology boosts torque an additional 25% to 40%. Custom motors are available to meet specific application needs including: modified shafts, connectors, lead-screws, and components mounted to the shaft.

### N/K Series Benefits

- More torque to drive heavy loads
- Smaller drives result in a lower system cost
- Higher efficiency enables lower operating costs

Size 34 N/K		2 Phase, 1.8° Step Motors. Frame size: 3.4 inch, 87 mm					
	Series	Construction		Holding Torque (Motor Mounted)		Length	
	Style	Stacks	Bipolar		in	mm	<ul style="list-style-type: none"> <li>• Captured heavy duty bearings</li> <li>• High voltage insulation system</li> <li>• Options: Terminal box MS connectors Rear shaft Encoder Front shaft seal</li> </ul>
			oz-in	Nm			
K31	Enhanced	1	830	5.9	3.7	94	
K32		2	1530	10.8	5.22	133	
K33		3	2200	15.6	6.74	171	
K34		4	2770	19.6	8.25	210	
N31	Un-Enhanced	1	650	4.6	3.7	94	
N32		2	1220	8.6	5.22	133	
N33		3	1760	12.4	6.74	171	
N34		4	2170	15.3	8.25	210	

Size 42 N/K		2 Phase, 1.8° Step Motors. Frame size: 3.4 inch, 87 mm					
	Series	Construction		Holding Torque (Motor Mounted)		Length	
	Style	Stacks	Bipolar		in	mm	<ul style="list-style-type: none"> <li>• Captured heavy duty bearings</li> <li>• High voltage insulation system</li> <li>• Options: Terminal box MS connectors Rear shaft Encoder Front shaft seal</li> </ul>
			oz-in	Nm			
K41	Enhanced	1	2090	14.8	3.89	99	
K42		2	4000	28.2	5.91	150	
K43		3	5650	39.9	7.92	201	
N41	Un-Enhanced	1	1630	11.5	3.89	99	
N42		2	3140	22.2	5.91	150	
N43		3	4340	30.6	7.92	201	

Note: For complete Size 34 and 42 N/K model nomenclature, refer to pages 79 and 80 respectively.



# Optimized Solutions

**With Kollmorgen, there's always a way.** Because we have decades of experience in developing optimized solutions for motion applications, you can be confident that we can provide the answer to your motion challenges. We have a huge breadth of standard products that can be modified in varying degrees, or we can develop custom motor and electronic products for true optimization.

Working with our proven portfolio of products, we can deliver solutions quickly, often with recognized cost efficiencies and reduced lead times. That means rapid prototyping, a shorter design cycle and getting to market faster. We do it all, because motion matters.

Sold & Serviced By:

 **ELECTROMATE**

Toll Free Phone (877) SERV098

Toll Free Fax (877) SERV099

[www.electromate.com](http://www.electromate.com)

[sales@electromate.com](mailto:sales@electromate.com)

---

### Optimized Solutions

Whether it's modifying a product from our standard catalog or a white sheet design for a custom solution, you can rely on decades of Kollmorgen expertise to solve your motion challenges and help your machine stand out from the crowd.

---

### Modified Standard

Because our application expertise runs deep and our product portfolio is so broad, we can take any standard product and modify it a lot or a little to suit many needs – in a very rapid time frame. This approach ensures quality, performance and reliability by leveraging our proven track record.

Kollmorgen application engineers have a great deal of experience helping OEM engineers achieve their objectives. Typical modifications include shaft alterations, feedback type, mounting dimensions, connectors, and making components more rugged, vacuum-rated, radiation- and explosion-proof.

---

### Custom Products

With motion as our core capability, we bring a significant history of innovation to today's engineering challenges. We leverage our design and engineering excellence and technical knowledge to deliver creative new solutions for virtually any need. Our vast experience also helps us deliver a custom product in a surprisingly short time. If you can conceive it, we can make it happen.

Sold & Serviced By:



Toll Free Phone (877) SERV098

Toll Free Fax (877) SERV099

[www.electromate.com](http://www.electromate.com)

[sales@electromate.com](mailto:sales@electromate.com)

# Structured Development Process

Working from our broad standard product portfolio, we create fully optimized solutions through the combination of off-the-shelf products, modified standard products and completely custom components. Our proven components and technology are the foundation for all of our solutions, expediting the design cycle and ensuring optimum performance for any application.

We follow a strict and efficient development process from initial concept to volume production. This ensures that products we develop meet customer needs, are cost effective to manufacture and move quickly from prototype to production. Customer involvement is key to our process, with ongoing collaboration throughout the initiative and multiple approval points to ensure a smooth, successful design cycle from beginning to end.

## Why You Should Partner with Kollmorgen

- Experienced application engineers help define a customer's needs and identify the optimal Kollmorgen products and technologies
- Products optimized or developed by cross-functional teams to meet customer needs
- Rapid prototyping
- Smooth transition from prototype designs to sustainable and cost effective manufacturing
- Industry-proven quality, performance, and delivery
- Proven technology building blocks mitigate risks of customization

## Optimized Solutions Process

Comprehensive design, manufacture and test capabilities ensure the end product meets the customer performance specifications and quality requirements. Our skilled engineering team works directly with each customer throughout the process, quickly taking the prototype to full production.

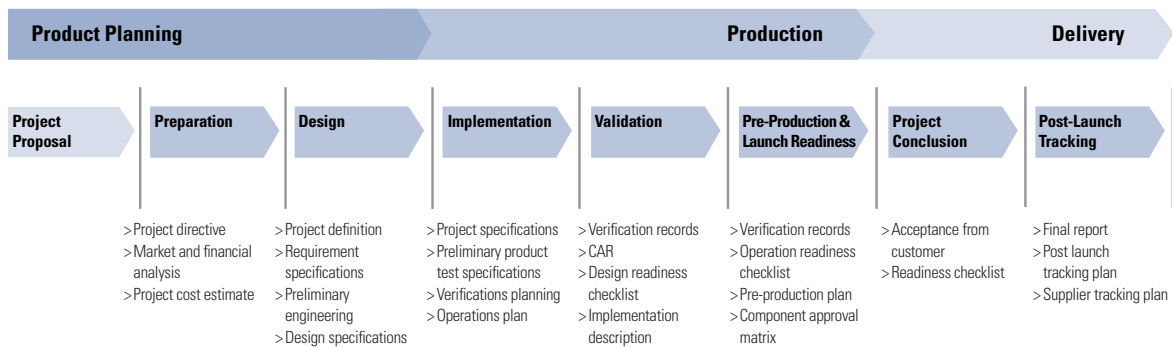

Sold & Serviced By:



Toll Free Phone (877) SERV098

Toll Free Fax (877) SERV099

[www.electromate.com](http://www.electromate.com)

[sales@electromate.com](mailto:sales@electromate.com)



# Proven Design Capabilities

## Motor Solutions

- Brushed, brushless and stepper motor building blocks used in frameless or housed configurations
- Designed for agency compliance (UL, CE)
- Voltage ratings from 48 Vdc – 600 Vdc, with capabilities in 800 Vdc and up
- Continuous torques from 0.5 Nm – 29,000 Nm
- Proven performance and reliability in a customizable package

## Drive Solutions

- Board-level or packaged solutions supporting single to multi-axis configurations
- Brushed or brushless servo drives, stepper, AC induction control
- Integrated controller and communications options
- Designed for agency approvals (UL 508C, EN 50178, EN 61000-6-6, EN 61800-3, CISPR 14-1, and others available)
- Proprietary technology and software can be embedded into the drive



Medical diagnostics drive optimized for form-factor, I/O and EMC

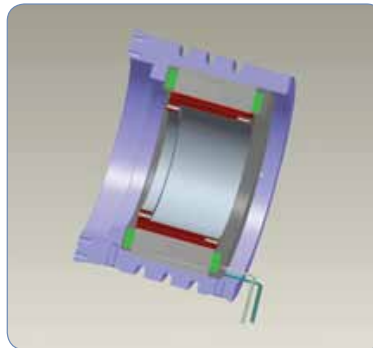

Frameless direct drive rotary motor with water cooling features

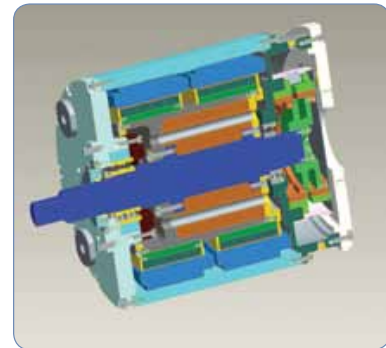

Custom submersible motor

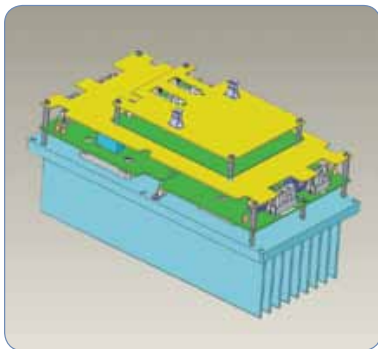

2-axis drive for high-power robotics, optimized for form-factor and communications interface



200 kW electric starter/generator

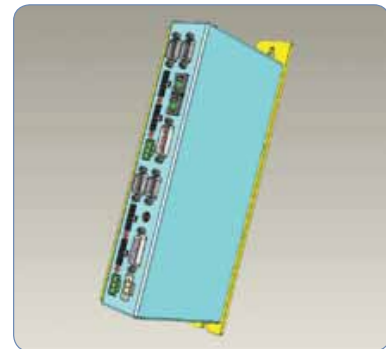

4-axis stepper drive using SynqNet

## Motors and Electronics

Optimized for	Application
Reliability	Implantable heart pumps, military, remote equipment
Precision	Pick and place, satellite tracking, film processing
Package size	Medical imaging, ground based telescopes, aircraft instrumentation
Weight	Land vehicles, portable equipment, aircraft
Smooth operation	Medical respirators, high precision robotics, printing and textile machines
Harsh environments	Deep sea, outer space, high shock and vibration, extreme temperatures

Sold & Serviced By:



Toll Free Phone (877) SERV098

Toll Free Fax (877) SERV099

[www.electromate.com](http://www.electromate.com)

[sales@electromate.com](mailto:sales@electromate.com)

# Cables by Motor Type

## Value Line Cables by Motor Type

Model	Power Cable	Power Cable with Brake Leads	SFD	EnDat2.2, 01 & BiSS
AKM to 6 Amps	VP-507BEAN-XX	VP-508CFAN-XX	VF-DA0474N-XX	VF-SB4474N-XX
AKM to 12 Amps	VP-508CEAN-XX	VP-508CFAN-XX	VF-DA0474N-XX	VF-SB4474N-XX
AKM to 20 Amps	VP-508DEAN-XX	VP-508DFAN-XX	VF-DA0474N-XX	VF-SB4474N-XX
CDDR to 6 Amps	VP-507BEAN-XX	n/a	n/a	VF-SB4474N-XX
CDDR to 12 Amps	VP-508CEAN-XX	n/a	n/a	VF-SB4474N-XX
CDDR to 20 Amps	VP-508DEAN-XX	n/a	n/a	VF-SB4474N-XX
DDR to 6 Amps	VP-507BEAN-XX	n/a	n/a	VF-SB4474N-XX
DDR to 12 Amps	VP-508CEAN-XX	n/a	n/a	VF-SB4474N-XX
DDR to 20 Amps	VP-508DEAN-XX	n/a	n/a	VF-SB4474N-XX

XX = length in meters (1, 3, 6, 9, 12) Example: VP-507BEAN-09 (9 meter cable).  
Other feedback choices are available. Contact customer support for details.

## Flex Line Cables by Motor Type

Model	Power Cable	Power Cable with Brake Leads	SFD	EnDat2.2, 01 & BiSS
AKM to 12 Amps	CP-507CCAN-XX-X	CP-507CDAN-XX-X	CF-DA0374N-XX-X	CF-SB7374N-XX-X
AKM to 20 Amps	CP-508DCAN-XX-X	CP-508DDAN-XX-X	CF-DA0374N-XX-X	CF-SB7374N-XX-X
AKM to 24 Amps	CP-508EDBN-XX-X	CP-508EDBN-XX-X	CF-DA0374N-XX-X	CF-SB7374N-XX-X
CDDR to 12 Amps	CP-507CCAN-XX-X	n/a	n/a	CF-SB7374N-XX-X
CDDR to 20 Amps	CP-508DCAN-XX-X	n/a	n/a	CF-SB7374N-XX-X
DDR to 12 Amps	CP-507CCAN-XX-X	n/a	n/a	CF-SB7374N-XX-X
DDR to 20 Amps	CP-508DCAN-XX-X	n/a	n/a	CF-SB7374N-XX-X

Note 1: XX-X = length in half-meters up to 50 meters (1, 3, 6, 9, 12 standard) Example: CP-507CCAN-03-5 (3.5 meter cable).  
Note 2: Other feedback choices are available. Contact customer support for details.  
Note 3: Other lengths are available. Contact customer support for details.  
Note 4: Refer to page 19 for cable specifications.

Sold & Serviced By:

 **ELECTROMATE**

Toll Free Phone (877) SERV098

Toll Free Fax (877) SERV099

[www.electromate.com](http://www.electromate.com)

[sales@electromate.com](mailto:sales@electromate.com)

## MODEL NOMENCLATURE

# AKD Servo Drive

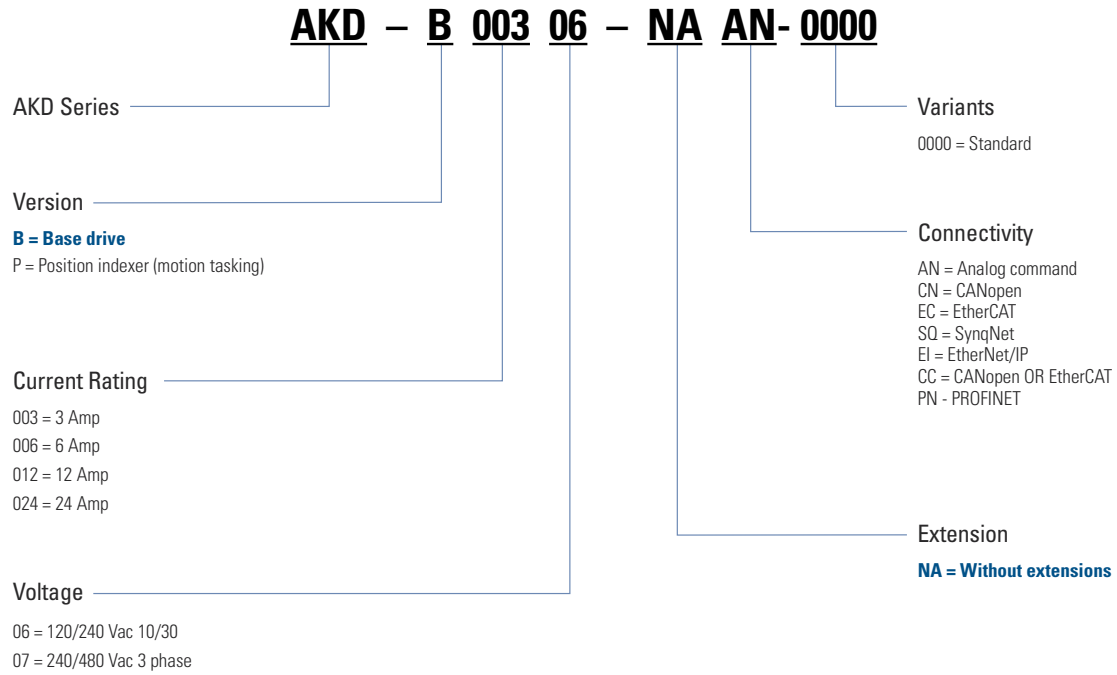

Note: Options shown in bold blue text are considered standard.

Sold & Serviced By:

 **ELECTROMATE**

Toll Free Phone (877) SERV098

Toll Free Fax (877) SERV099

[www.electromate.com](http://www.electromate.com)

[sales@electromate.com](mailto:sales@electromate.com)

# AKM Brushless Servomotor

MODEL NOMENCLATURE

**AKM 4 2 E - E K C N C- 00**

AKM Series

Motor Frame Size  
1, 2, 3, 4, 5, 6, 7, 8

Rotor Stack Length  
1, 2, 3, 4, 5

Winding Type

Mount

- A = International standard mount**
- B = NEMA mount
- C = Alternative standard mount
- D = Alternative standard mount
- E = Alternate NEMA mount
- M = "A mount" with reinforced bearing, AKM8
- S = Special
- T = "C mount" with alternative reinforced bearing, AKM8

Shaft

- C = Closed keyway
- K = Open keyway
- N = Smooth shaft**
- S = Special

Customization/Seal

Feedback Device

- 1- = 1024 PPR digital encoder with commutation (AKM1-7)
- 2- = 2048 PPR digital encoder with commutation (AKM1-7)
- C- = Smart Feedback Device (SFD) (available across family)**
- R- = Resolver
- AA = BiSS single-turn absolute (AKM2-8)
- AB = BiSS multi-turn absolute (AKM2-8)
- DA = Single-turn absolute sine encoder (EnDat2.2, 01) (AKM2-8)
- DB = Multi-turn absolute sine encoder (EnDat2.2, 01) (AKM2-8)
- LA = Inductive single-turn (AKM2-7)
- LB = Inductive multi-turn (AKM2-7)
- S = Special

Brake

Connectors

- B = Dual motor-mounted rotatable IP65 connectors (AKM2 only)
- C = 0.5 m shielded cables with IP65 connectors (AKM1, 2), motor-mounted rotatable IP65 connectors (AKM3-7)**
- D = Single angular connector (AKM2, 3, 4)
- G = Straight motor-mounted IP65 connectors (AKM2-7)
- H = Motor-mounted IP65 power connector size 1.5 (AKM74Q & AKM82)
- M = 0.5 m shielded cable w/ IP20 connectors (AKM1, 2, 3, 4 models, less than 6 amps)
- P = 0.5 m shielded cable w/ IP20 connectors (AKM1, 2, 3, 4 models with SFD and no brake, less than 6 amps)
- S = Special
- T = Terminal box for power and feedback connector size 1.0 (AKM8)

Note: Options shown in bold blue text are considered standard.

Sold & Serviced By:  
**ELECTROMATE**

Toll Free Phone (877) SERV098  
Toll Free Fax (877) SERV099  
www.electromate.com  
sales@electromate.com

# Cartridge Direct Drive Rotary (DDR) Motor

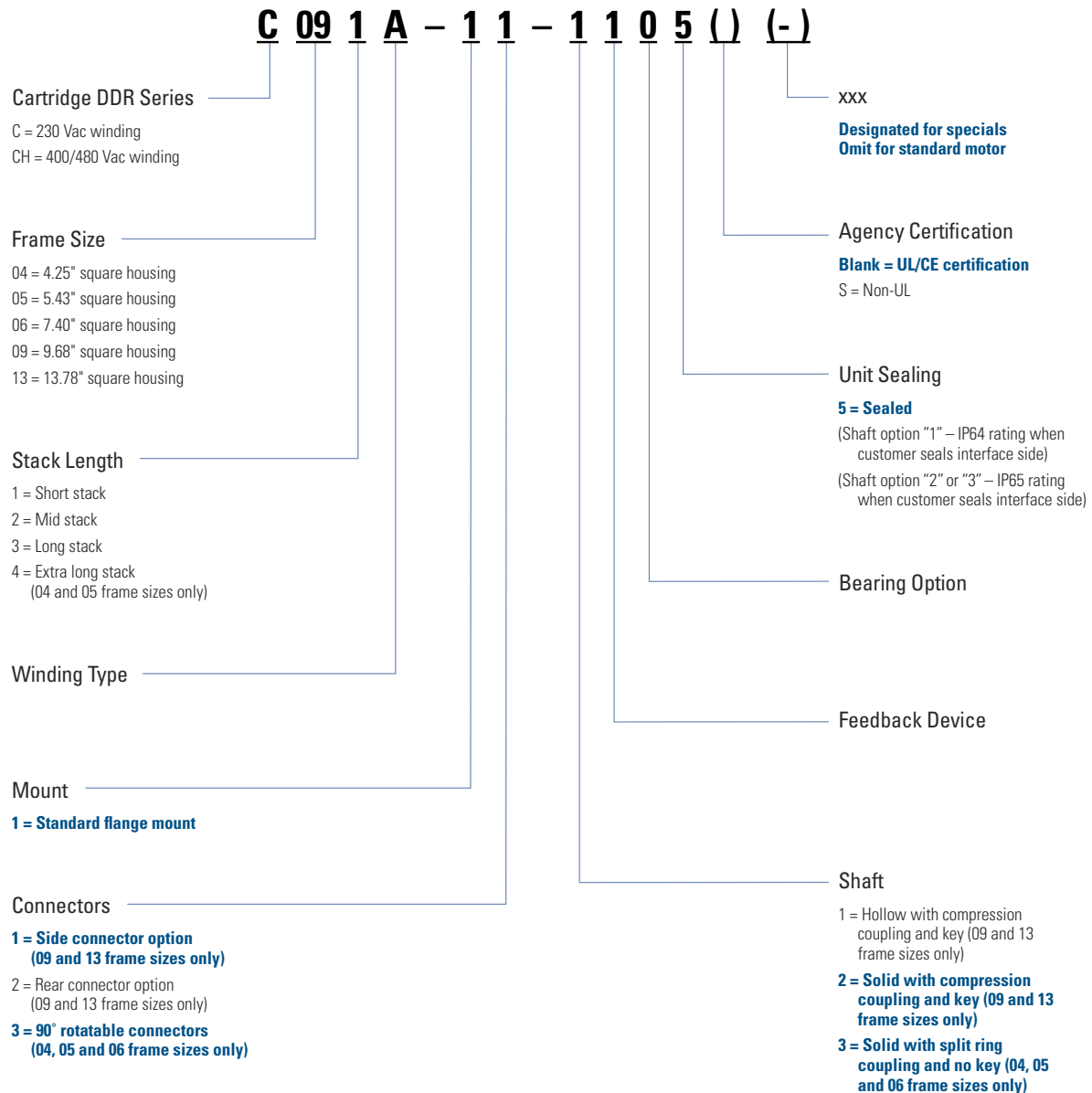

Note: Options shown in bold blue text are considered standard.

# Housed Direct Drive Motors D(H) Series

MODEL NOMENCLATURE

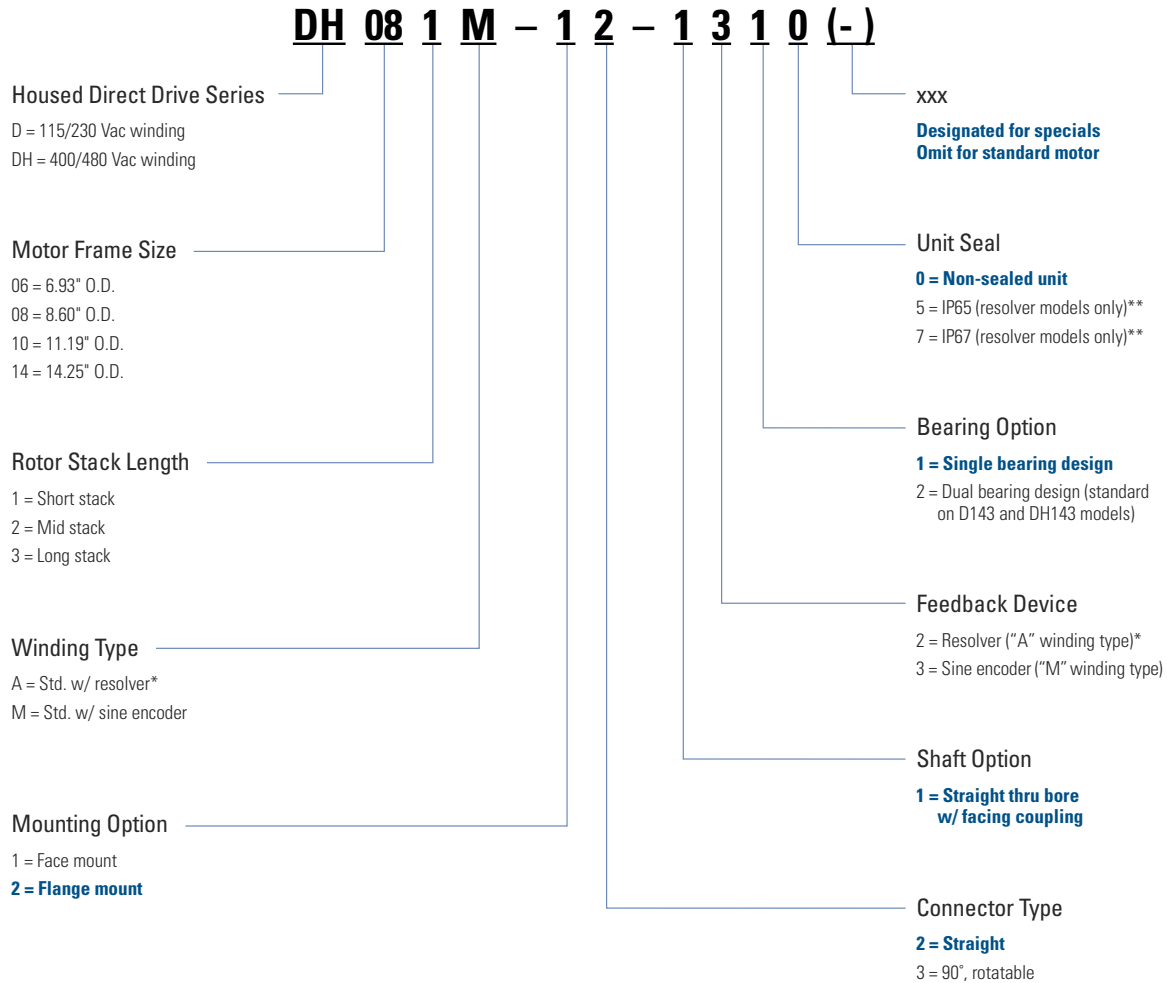

\* All models except D14x and DH14x.  
 \*\* Sealed motors with encoder feedback have longer axial length.  
 Note: Options shown in bold blue text are considered standard.

# DS Series Precision Table

**DS Series** – **Stroke Length** – **Grade** – **Ball screw Lead** – **Motor Type\*** – **Motor Options** – **Motor Mounts** – **Couplings** – **Motor Orient.** – **Limit Sensors** – **Home Switch** – **Shaft End Opt.** – **Linear Decoder** – **Options**

**DS4** – **250** – **C** – **5G** – **AKM23D** – **BNC** – **(-)** – **OE6** – **PR6E** – **LN1** – **H0** – **(-)** – **EO** – **CLN**

DS Series

### Stroke Length

50 = 50 mm total stroke	DS4 only
100 = 100 mm total stroke	
150 = 150 mm total stroke	DS4 only
200 = 200 mm total stroke	
250 = 250 mm total stroke	DS4 only
300 = 300 mm total stroke	
350 = 350 mm total stroke	DS4 only
400 = 400 mm total stroke	
450 = 450 mm total stroke	DS4 only
500 = 500 mm total stroke	
550 = 550 mm total stroke	DS4 only
600 = 600 mm total stroke	
700 = 700 mm total stroke	DS6 only
800 = 800 mm total stroke	DS6 only
900 = 900 mm total stroke	DS6 only
1000 = 1000 mm total stroke	DS6 only
1250 = 1250 mm total stroke	DS6 only
1500 = 1500 mm total stroke	DS6 only
1750 = 1750 mm total stroke	DS6 only
2000 = 2000 mm total stroke	DS6 only

### Grade

**C = Commercial grade**  
P = Precision grade\*\*

### Ball screw Lead

5G = 5 mm/rev	
10G = 10 mm/rev	
25G = 25 mm/rev	DS6 only

### Motor Type\*

### Motor Options\*

<b>B</b> ■ ■ = Rotatable IP65 connectors	
<b>C</b> ■ ■ = 0.5 m shielded cables w/ IP65 connectors	AKM2 only
<b>C</b> ■ ■ = Rotatable IP65 connectors	AKM2 only
<b>N</b> ■ ■ = No brake	AKM4, AKM5 only
<b>2</b> ■ ■ = 24 Vdc power-off holding brake	
<b>R</b> ■ ■ = Resolver	
<b>2</b> ■ ■ = 2048 LPR incremental comm. encoder	
<b>C</b> ■ ■ = Smart Feedback Device (SFD)	
<b>DA</b> ■ ■ = Single-turn absolute sine encoder, EnDat2.2, 01	
<b>DB</b> ■ ■ = Multi-turn absolute sine encoder, EnDat2.2, 01	

### Additional Options

P1 = Standard pinning of x-axis carriage  
CLN = Cleanroom prep – class 100  
**Omit for no additional options**

### Linear Decoder

### Shaft End Options

BS = Brake on ballscrew,  
24 Vdc power-off  
ES = Rotary encoder on ballscrew,  
1250 line  
**Omit for no additional options**

### Home Switch

**H0 = No home sensor**  
HN1 = Home, NPN type normal open  
HN2 = Home, NPN type normal closed  
HP1 = Home, PNP type normal open  
HP2 = Home, PNP type normal closed

### Limit Sensors

**L0 = No end-of-travel limits**  
LN1 = Limits, NPN type normal open  
LN2 = Limits, NPN type normal closed  
LP1 = Limits, PNP type normal open  
LP2 = Limits, PNP type normal closed

### Motor Orientation & Pulley Bore (Parallel Models)

PR6E = Parallel right  
PL6E = Parallel left  
PU6E = Parallel under  
**Omit if parallel model is not preferred**

### Couplings (Inline Models)

OE6 = Oldham style, 3/8" bore (AKM2X)  
OE8 = Oldham style, 1/2" bore (AKM4X) DS6 only  
BE6 = Bellows style, 3/8" bore (AKM2X)  
BE8 = Bellows style, 1/2" bore (AKM4X) DS6 only  
**Omit for parallel models**

### Motor Mounts

X23 = NEMA 23 mount  
X34 = NEMA 34 mount DS6 only  
**Omit if motor option is used**

\* Refer to Alternate AKM servomotor and electric cylinder systems table on page 72. Contact customer support for AKM combinations outside of those listed.

\*\* Extended lead time required.

Note 1: Options shown in bold blue text are considered standard.

Note 2: Contact customer support for price and lead time on all non-standard features.

Sold & Serviced By:



Toll Free Phone (877) SERV098

Toll Free Fax (877) SERV099

www.electromate.com

sales@electromate.com

# Alternate AKM Servomotor and Electric Cylinder Systems Table

MODEL NOMENCLATURE

For use when AKM servo motor is not included as part of electric cylinder model number.					
Electric Cylinder	AKM Frame	AKM Motor Model #	* Allowable AKM stack lengths	** Kollmorgen Motor Mount Code	Example Motor
N2	AKM2	AKM2XX-EFXXX	AKM21, 22, 23	IDR60 (C OR X)	AKM23D-EFCNC-00
EC1	AKM1	AKM1XX-ANXXX	AKM11, 13	IDR67 (C OR X)	AKM11B-ANCNC-00
EC2	AKM2	AKM2XX-EFXXX	AKM21, 22, 23	IDR60 (C OR X)	AKM23D-EFCNC-00
EC3	AKM2	AKM2XX-EFXXX	AKM21, 22, 23	IDR60 (C OR X)	AKM23D-EFCNC-00
EC3	AKM4	AKM4XX-EKXXX	AKM41, 42	IDR61 (C OR X)	AKM42G-EKCNR-00
EC4	AKM4	AKM4XX-EKXXX	AKM41, 42, 43, 44	IDR61 (C OR X)	AKM42G-EKCNR-00
EC4	AKM5	AKM5XX-EKXXX	AKM51, 52	IDR62 (C OR X)	AKM52G-EKCN2-00
EC5	AKM4	AKM4XX-EKXXX	AKM41, 42, 43, 44	IDR61 (C OR X)	AKM44G-EKCNR-00
EC5	AKM5	AKM5XX-EKXXX	AKM51, 52	IDR62 (C OR X)	AKM52G-EKCN2-00

\* Based on maximum torque capacity, consult customer support for other combinations. Review application for inertia mismatch when considering motor options.

\*\* We mount Kollmorgen motors without a fee. Must have "C" as motor mount code if you desire Kollmorgen to mount motor at factory. For non-Kollmorgen motors contact customer support for pricing.

NEMA Mounting Table		
Frame	Series	P/N Callout
NEMA 17	EC	17 (X or C)
NEMA 23	N, N2, EC2, EC3, R2A, R3	23 (X or C)
NEMA 34	N, N2, EC2, EC3, EC4, EC5, R2A, R3, R4, DS4, DS6	34 (X or C)
NEMA 42	EC4, EC5, R4, DS4, DS6	42 (X or C)

Example P/N: EC2-X-rest of pn-23X

Sold & Serviced By:



Toll Free Phone (877) SERV098

Toll Free Fax (877) SERV099

[www.electromate.com](http://www.electromate.com)

[sales@electromate.com](mailto:sales@electromate.com)



# Electric Cylinders EC Series

**EC Series** – **Motor Type\*** – **Motor Options** – **Drive Ratio** – **Screw Lead** – **Stroke Length** – **Cylinder Mounting** – **Rod Ends** – **Options** – **Cable Option**  
**EC2** – **AKM23D** – **BNR** – **10** – **05B** – **300** – **MP2** – **FT1M** – **(-)** – **CO**

## EC Series

EC1  
EC2  
EC3  
EC4  
EC5

## Stroke Length\*\*

## Available

All  
All  
All  
All  
EC2, EC3, EC4, EC5  
EC2, EC3, EC4, EC5  
EC2, EC3, EC4, EC5  
EC2, EC3, EC4, EC5  
EC3, EC4, EC5  
EC4, EC5  
EC4, EC5

## Motor Type\*

CTP12 = CTP12xLF10MMA00 stepper motor  
AKM11B = AKM11B-ANCxx-00 brushless servo  
AKM13C = AKM13C-ANCxx-00 brushless servo  
AKM23D = AKM23D-EFxxx-00 brushless servo  
AKM23C = AKM23C-EFxxx-00 brushless servo  
AKM42G = AKM42G-EKxxx-00 brushless servo  
AKM42E = AKM42E-EKxxx-00 brushless servo  
AKM52G = AKM52G-EKxxx-00 brushless servo  
AKM52L = AKM52L-EKxxx-00 brushless servo

## Available

EC1  
EC1  
EC1  
EC2, EC3  
EC2, EC3  
EC3, EC4, EC5  
EC3, EC4, EC5  
EC4, EC5  
EC4, EC5

## Motor Options

**B ■ ■ ■** = Rotatable IP65 connectors  
**C ■ ■ ■** = 0.5 m shielded cables w/ IP65 connectors  
**C ■ ■ ■** = Rotatable IP65 connectors  
**■ N ■ ■** = No brake  
**■ 2 ■ ■** = 24 Vdc power-off holding brake  
**■ ■ R** = Resolver  
**■ ■ 2** = 2048 LPR incremental comm. encoder  
**■ ■ C** = Smart Feedback Device (SFD)  
**■ ■ ■ ■** = Omit field for CTP12

## Available

AKM2  
AKM1, AKM2  
AKM4, AKM5  
AKM1, AKM2, AKM4, AKM5  
AKM2, AKM4, AKM5  
AKM1, AKM2, AKM4, AKM5  
AKM1, AKM2, AKM4, AKM5  
AKM1, AKM2, AKM4, AKM5  
CTP12

## Drive Ratio

10 = 1.0:1 drive belt/pulley (EC1 – helical)  
15 = 1.5:1 drive belt/pulley  
20 = 2.0:1 drive belt/pulley (EC1 – helical)  
40 = 4.0:1 helical gears  
50 = 5.0:1 helical gears  
70 = 7.1:1 helical gears  
100 = 10.0:1 helical gears  
10L = 1.0:1 inline coupling (direct 1:1 coupling is the only ratio available for inline models)

## Available

All  
EC2, EC3, EC4, EC5  
Not valid for EC3-AKM42  
EC1 only  
EC2, EC3, EC4, EC5  
EC3 only  
EC2, EC4, EC5  
All

## Screw Lead

03B = 0.125 in/rev ballscrew  
05B = 5 mm/rev ballscrew  
10B = 10 mm/rev ballscrew  
16B = 16 mm/rev ballscrew  
25B = 25 mm/rev ballscrew  
32B = 32 mm/rev ballscrew  
04A = 4 mm/rev lead screw

## Available

EC1  
EC2, EC3  
EC3, EC4, EC5  
EC2, EC3  
EC4  
EC5  
EC2, EC3

## Cylinder Mounting

MF1 = Front rectangular flange  
MF1E = Front rectangular flange (English)  
MF1M = Front rectangular flange (metric)  
MF2 = Rear rectangular flange  
MF2E = Rear rectangular flange (English)  
MF2M = Rear rectangular flange (metric)  
MF3 = Front & rear rectangular flange  
MF3E = Front & rear rectangular flange  
MF3M = Front & rear rectangular flange  
MP2 = Rear double clevis without pivot base  
MP3 = Rear double clevis with pivot base  
MS1 = Side end angle  
MS2 = Side lugs  
**MS6M = Side tapped holes (metric)**  
MS6E = Side tapped holes (English)  
MT4 = Trunnion

## Available

## Rod Ends

FC2 = Clevis (includes MT1M)  
FS2 = Spherical joint (includes FT1M)  
FT1M = Female thread (metric)  
FT1E = Female thread (English)  
**MT1M = Male thread (metric)**  
MT1E = Male thread (English)

## Available

All  
All  
All  
EC2, EC3, EC4, EC5  
**All**  
EC2, EC3, EC4, EC5

## Options\*\*\*

**(add multiple in the following sequence, omit if no options required)**

BA24 = 24 Vdc brake on actuator (EC1 only, not available with 10L ratio or MS1 mounting options)  
BS24 = 24 Vdc brake on ballscrew (not available with EC1 or 10L ratio, or with MF2(x), MF3(x), MS1, MP2(x), MP3(x) mounting options)  
BS115 = 115 Vac brake on ballscrew (not available with EC1 or 10L ratio, or with MF2(x), MF3(x), MS1, MP2(x), MP3(x) mounting options)  
PB = Protective boot\*  
L = Linear potentiometer (only valid through 600 mm stroke, standard lengths)

## Cable

**CO = No cable supplied, motor includes connectors.**  
Default for all AKM servomotors; select Kollmorgen cables based on motor/drive pairing.

\* Refer to Alternate AKM servomotor and electric cylinder systems table on page 72. Contact customer support for AKM combinations outside of those listed.

\*\* For custom lengths round up to next standard incremental plus add standard cut fee.

\*\*\* Contact customer support for non-standard pricing and lead times.

Note: Options shown in bold blue text are considered standard.

# Electric Cylinders N2 Series

MODEL NOMENCLATURE

**N2** – **AKM23D** – **BNR** – **15** – **5B** – **8** – **MP2** – **FT1M** **(-)** – **CO**

N2 Series

Motor Type\*

AKM23D = AKM23D-EFxxx-00 brushless servo  
AKM23C = AKM23C-EFxxx-00 brushless servo

- B ■ ■ = Rotatable IP65 connectors
- C ■ ■ = 0.5 m shielded cables w/ IP65 connectors
- N ■ = No brake
- 2 ■ = 24 Vdc power-off holding brake
- ■ R = Resolver
- ■ 2 = 2048 LPR incremental comm. encoder
- ■ C = Smart Feedback Device (SFD)

Drive Ratio

- 10 = 1.0:1 drive belt/pulley
- 15 = 1.5:1 drive belt/pulley
- 20 = 2.0:1 drive belt/pulley
- 25 = 2.5:1 helical gears
- 35 = 3.5:1 helical gears
- 120 = 12.0:1 helical gears
- 10L = 1.0:1 inline coupling (direct 1:1 coupling is the only ratio available for inline models)

Screw Pitch, Type

- 2B = 2 rev/inch ballscrew
- 5B = 5 rev/inch ballscrew
- 5A = 5 rev/inch lead screw
- 8A = 8 rev/inch lead screw

Stroke Length\*\*

- 2 = 2 inch total stroke
- 4 = 4 inch total stroke
- 6 = 6 inch total stroke
- 8 = 8 inch total stroke
- 12 = 12 inch total stroke
- 18 = 18 inch total stroke (requires -DB option, effective stroke is 16.5")
- 24 = 24 inch total stroke (requires -DB option, effective stroke is 22.5")
- nn.n = Custom stroke lengths available in 0.1 inch increments

\* Refer to Alternate AKM servomotor and electric cylinder systems table on page 72. Contact customer support for AKM combinations outside of those listed.

\*\* For custom lengths round up to next standard incremental plus add standard cut fee.

\*\*\* Contact customer support for non-standard pricing and lead times.

Note: Options shown in bold blue text are considered standard.

Cable

**CO = No cable supplied, motor includes connectors. Default for all AKM servomotors; select Kollmorgen cables based on motor/drive pairings.**

Options\*\*\*

**(add multiple in the following sequence, omit if no option required)**

- DB = Dual front braking
- BS24 = 24 Vdc brake on lead screw (not available with 10L ratio, or with MF2, MF3, MS2, MP2, MP3 mounting options)
- PB = Protective boot
- W = Water resistant
- F = Sub-freezing temperature
- H = High temperature prep
- L = Linear potentiometer (only for valid std. lengths)

Rod Ends

- FC2 = Clevis (includes MT1M)**
- FS2 = Spherical joint (includes FT1M)
- FT1M = Female thread (metric)
- FT1E = Female thread (English)
- MT1M = Male thread (metric)
- MT1E = Male thread (English)

Cylinder Mounting

- MF1 = Front rectangular flange**
- MF2 = Rear rectangular flange
- MF3 = Front & rear rectangular flange
- MP2 = Rear double clevis without pivot base
- MP3 = Rear double clevis with pivot base
- MS1 = Side end angle
- MS2 = Side lugs
- MS6M = Side tapped holes (metric)
- MS6E = Side tapped holes (English)
- MT4 = Trunion

Sold & Serviced By:

 **ELECTROMATE**

Toll Free Phone (877) SERV098

Toll Free Fax (877) SERV099

[www.electromate.com](http://www.electromate.com)

[sales@electromate.com](mailto:sales@electromate.com)



# Micron™ TRUE Planetary™ Gearhead

MODEL NOMENCLATURE

**DTR 115 – 005 – 0 – ( )**

**Gearhead Series**

- NT = NemaTRUE™
- NTP = NemaTRUE PLUS™
- NTR = NemaTRUE 90™
- XT = XTRUE™
- ET = EverTRUE™
- DT = DuraTRUE™
- DTR = DuraTRUE 90™
- DTRS = DuraTRUE™ slimline
- DTRH = DuraTRUE™ hollow shaft
- DTRD = DuraTRUE™ dual shaft
- VT = ValueTRUE™
- VTR = ValueTRUE 90™
- UT = UltraTRUE™
- UTR = UltraTRUE 90™

**Motor Model Number**

RediMount number (if available)  
or motor manufacturer and model number

**Customer Options**

- 0 = None
- S = Special
- H = High precision  
(for NemaTRUE™ product line only)

**Gearhead Ratio**

See ratio availability in corresponding  
gearhead section (pp 51-53)

**Gearhead Size**

- NemaTRUE™**
- NemaTRUE PLUS™**
- NemaTRUE 90™**
- 17 = Size 17
- 23 = Size 23
- 34 = Size 34
- 42 = Size 42
- 60 = Size 60
- 90 = Size 90
- 115 = Size 115

- XTRUE™**
- 040 = Size 40
- 060 = Size 60
- 080 = Size 80
- 120 = Size 120
- 160 = Size 160

- EverTRUE™**
- 10 = Size 10
- 14 = Size 14
- 18 = Size 18

- DuraTRUE™**
- DuraTRUE 90™**
- DuraTRUE™ Slimline**
- DuraTRUE™ Hollow Shaft**
- DuraTRUE™ Dual Shaft**
- 60 = Size 60
- 90 = Size 90
- 115 = Size 115
- 142 = Size 142

- ValueTRUE™**
- ValueTRUE 90™**
- 006 = Size 60
- 075 = Size 75
- 090 = Size 90
- 010 = Size 10
- 115 = Size 115
- 014 = Size 14
- 018 = Size 18
- 022 = Size 22

- UltraTRUE™**
- UltraTRUE 90™**
- 006 = Size 60
- 075 = Size 75
- 090 = Size 90
- 010 = Size 10
- 115 = Size 115
- 014 = Size 14
- 018 = Size 18
- 022 = Size 22 (UltraTRUE™ only)

Sold & Serviced By:



Toll Free Phone (877) SERV098  
Toll Free Fax (877) SERV099  
www.electromate.com  
sales@electromate.com

# P7000 Stepper Drive

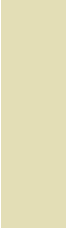

MODEL NOMENCLATURE

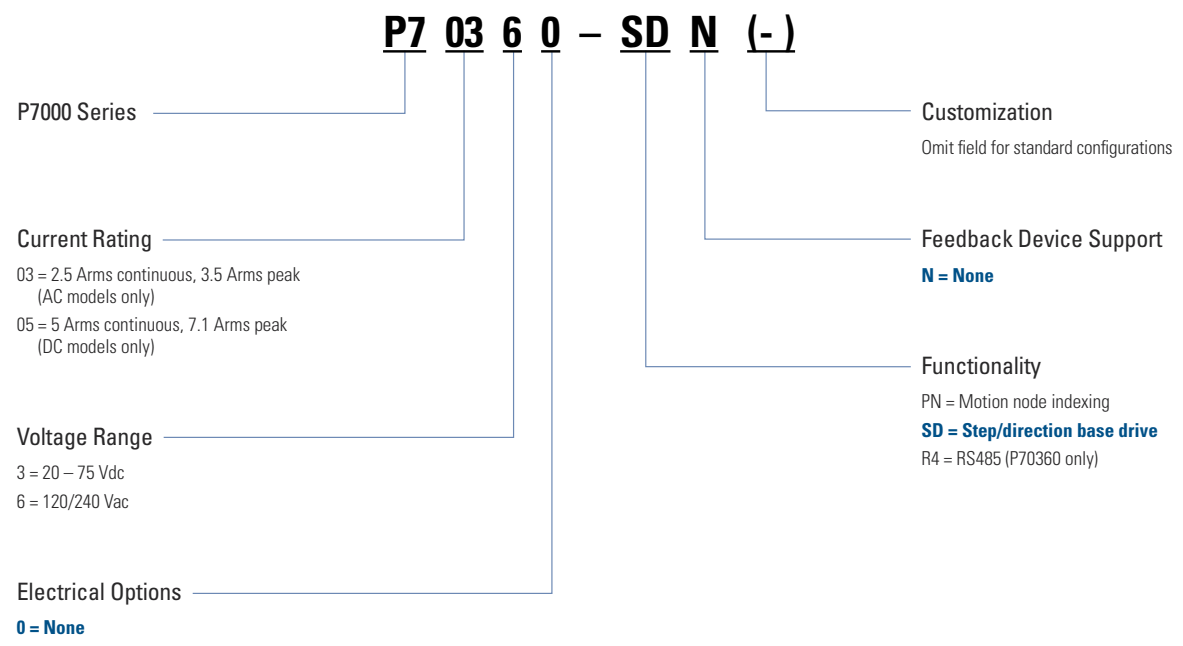

# CT Series Step Motor

MODEL NOMENCLATURE

**CTM 2 1 N L F 10 N AA 00**

## CT Series

CTM = Cool torque maximum series  
CTP = Cool torque performance series

## Frame Size

1 = Size 17 / 4.2 cm (CTP only)  
2 = Size 23 / 5.7 cm  
3 = Size 34 / 8.5 cm

## Length

0 = Short stack (CTP only)  
1 = 1 stack  
2 = 2 stacks  
3 = 3 stacks

## Mounting

N = NEMA through holes (size 23 & 34 only)  
E = English tapped holes (size 17 only)  
M = Metric tapped holes (size 17 only)

## Construction/Connection Style

**L = Leads**  
S = Special

## Number of Connections

**F = Four**  
S = Six

## Customization

**00 = Standard motor**  
Other numbers serially assigned for special motors

## Rear Options

**AA = None**  
EE = English rear shaft & encoder mounting holes (size 23 & 34 only)  
MA = Metric rear shaft (size 17 only)  
SS = Special

## Front Shaft Options

N = Round smooth shaft (size 23 only)  
F = Flat (size 23 only)  
K = Straight keyway (size 34 only)  
M = Metric (size 17 only)  
S = Special

## Winding Current

For 4 lead motors = bipolar current x10  
For 6 lead motors = unipolar current x10  
Examples:  
05 = 0.5 Amps  
10 = 1 Amp  
50 = 5 Amps  
00 = Special

Sold & Serviced By:



Toll Free Phone (877) SERV098  
Toll Free Fax (877) SERV099  
www.electromate.com  
sales@electromate.com

# NEMA 34 K and N Series Step Motor

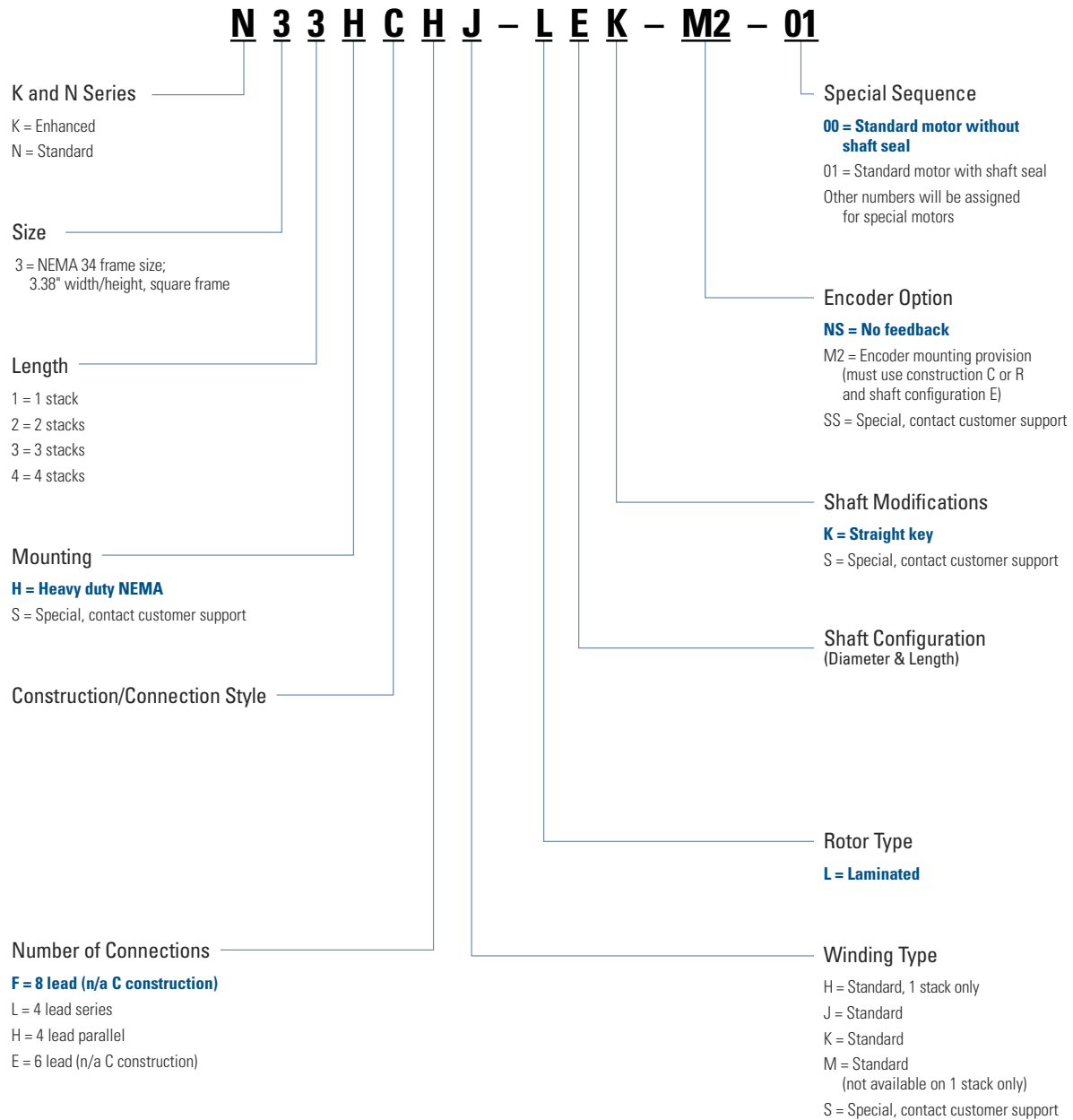

Sold & Serviced By:



Toll Free Phone (877) SERV098

Toll Free Fax (877) SERV099

[www.electromate.com](http://www.electromate.com)

[sales@electromate.com](mailto:sales@electromate.com)

# NEMA 42 K and N Series Step Motor

MODEL NOMENCLATURE

**K 4 3 H C H J - L E K - M2 - 01**

## K and N Series

K = Enhanced  
N = Standard

## Size

4 = NEMA 42 frame size;  
4.325" width/height, square frame

## Length

1 = 1 stack  
2 = 2 stack  
3 = 3 stack

## Mounting

**H = Heavy duty NEMA**  
S = Special, contact customer support

## Construction/Connection Style

**R = Regular/leadwire**  
C = System MS connector  
L = Splashproof/to terminal board via  
conduit connector: 1/2" NPSC pipe thread  
M = Splashproof/to terminal board via  
conduit connect: metric PG13.5 pipe thread  
S = Special, contact customer support

## Number of Connections

F = 8 lead (n/a C construction)  
L = 4 lead series  
H = 4 lead parallel  
E = 6 lead (n/a C construction)

## Special Sequence

**00 = Standard motor without shaft seal**  
01 = Standard motor with shaft seal  
Other numbers will be assigned for special motors

## Encoder Option

**NS = No feedback**  
M2 = Encoder mounting provision  
(must use construction C or R and shaft configuration E)  
SS = Special, contact customer support

## Shaft Modifications

**K = Straight key**  
S = Special, contact customer support

## Shaft Configuration (Diameter & Length)

## Rotor Type

**L = Laminated**

## Winding Type

J = Only on 1 stack  
K = N/A on 1 stack  
L = N/A on 1 stack  
N = N/A on 1 stack  
M = Standard  
S = Special, contact customer support

Sold & Serviced By:



Toll Free Phone (877) SERV098

Toll Free Fax (877) SERV099

[www.electromate.com](http://www.electromate.com)

[sales@electromate.com](mailto:sales@electromate.com)







# MOTIONEERING® Application Engine

**Introducing the Next Generation of Great Ideas** In this Windows®-based motor-sizing program takes a systems approach to the selection of brushless, DC servomotors, stepper motors and drives. MOTIONEERING application engine, available at [www.kollmorgen.com](http://www.kollmorgen.com), uses a project concept for the collection and saving of rotary and linear multi-axis load information. This provides the user the flexibility to sum the effects of multiple axes of motion for power supply and shunt regeneration sizing.

A wide variety of linear and rotary mechanisms are provided including lead screw, rack and pinion, conveyor, nip rolls, cylinder, rotary, and direct data-entry using unique sizing algorithms and product databases criteria.

The searchable database consists of hundreds of systems on product combinations including rotary housed and frameless brushless servomotors, direct drive rotary and linear brushless servomotors, linear positioners (electric cylinders, rodless actuators, and precision tables) and stepper systems.

The MOTIONEERING application engine also provides versatile units-of-measure selection options for mechanism and motion profile data-entry, with the ability to convert data into other available units. Online Help explains program functions and the definition of terms and equations used in the program.

## Features

- Group multiple mechanisms within a “project” – organize and combine data for power supply and regeneration sizing
- Types of mechanisms for analysis include lead screw, rack and pinion, conveyor, nip rolls, rotary and direct drive linear motor
- Motion profile options include simple triangle, 1/3-1/3-1/3 trapezoidal, variable traverse trapezoidal, and more
- Search results display shows color highlighted solution set of options for easy evaluation of system specifications and selection

## Supported Operating Systems

- Microsoft® Windows 2000, XP, Vista

## MOTIONEERING 6.0 includes

- Electric cylinder sizing and selection with AKM servomotor systems
- Rodless actuator with AKM servomotor systems (performance curves included)
- Precision table with AKM servomotor systems (performance curves included)
- PDF report functionality (includes application, drive, motor, positioner, and system specifications all in one easy-to-read report)

